

# FLASH MEMORY

CMOS

# 4M (512K × 8/256K × 16) BIT

## MBM29DL400TC-55/-70/-90/-12/MBM29DL400BC-55/-70/-90/-12

### ■ FEATURES

- **Single 3.0 V read, program, and erase**  
Minimizes system level power requirements
- **Simultaneous operations**  
Read-while-Erase or Read-while-Program
- **Compatible with JEDEC-standard commands**  
Uses same software commands as E<sup>2</sup>PROMs
- **Compatible with JEDEC-standard world-wide pinouts (Pin compatible with MBM29LV400TC/BC)**  
48-pin TSOP(I) (Package suffix: PFTN – Normal Bend Type, PFTR – Reversed Bend Type)
- **Minimum 100,000 program/erase cycles**
- **High performance**  
55 ns maximum access time
- **Sector erase architecture**  
Two 16K byte, four 8K bytes, two 32K byte, and six 64K bytes.  
Any combination of sectors can be concurrently erased. Also supports full chip erase.
- **Boot Code Sector Architecture**  
T = Top sector  
B = Bottom sector
- **Embedded Erase™ Algorithms**  
Automatically pre-programs and erases the chip or any sector
- **Embedded Program™ Algorithms**  
Automatically writes and verifies data at specified address
- **Data Polling and Toggle Bit feature for detection of program or erase cycle completion**
- **Ready/Busy output (RY/BY)**  
Hardware method for detection of program or erase cycle completion
- **Automatic sleep mode**  
When addresses remain stable, automatically switch themselves to low power mode.
- **Low V<sub>CC</sub> write inhibit ≤ 2.5 V**
- **Erase Suspend/Resume**  
Suspends the erase operation to allow a read in another sector within the same device

(Continued)

(Continued)

- **Sector protection**  
Hardware method disables any combination of sectors from program or erase operations
- **Sector Protection Set function by Extended sector protection command**
- **Fast Programming Function by Extended Command**
- **Temporary sector unprotection**  
Temporary sector unprotection via the  $\overline{\text{RESET}}$  pin.

## ■ PACKAGE

48-pin plastic TSOP (I)

Marking Side

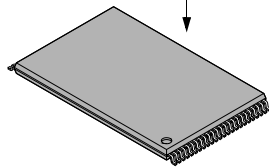

(FPT-48P-M19)

48-pin plastic TSOP (I)

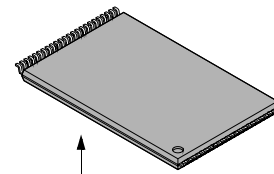

Marking Side

(FPT-48P-M20)

## ■ GENERAL DESCRIPTION

The MBM29DL400TC/BC are a 4M-bit, 3.0 V-only Flash memory organized as 512K bytes of 8 bits each or 256K words of 16 bits each. The MBM29DL400TC/BC are offered in a 48-pin TSOP(I) package. These devices are designed to be programmed in-system with the standard system 3.0 V  $V_{CC}$  supply. 12.0 V  $V_{PP}$  and 5.0 V  $V_{CC}$  are not required for write or erase operations. The devices can also be reprogrammed in standard EPROM programmers.

MBM29DL400TC/BC provides simultaneous operation which can read a data while program/erase. The simultaneous operation architecture provides simultaneous operation by dividing the memory space into two banks. The device can allow a host system to program or erase in one bank, then immediately and simultaneously read from the other bank.

The standard MBM29DL400TC/BC offer access times 55 ns and 120 ns, allowing operation of high-speed microprocessors without wait states. To eliminate bus contention the devices have separate chip enable ( $\overline{CE}$ ), write enable ( $\overline{WE}$ ), and output enable ( $\overline{OE}$ ) controls.

The MBM29DL400TC/BC are pin and command set compatible with JEDEC standard E<sup>2</sup>PROMs. Commands are written to the command register using standard microprocessor write timings. Register contents serve as input to an internal state-machine which controls the erase and programming circuitry. Write cycles also internally latch addresses and data needed for the programming and erase operations. Reading data out of the devices is similar to reading from 5.0 V and 12.0 V Flash or EPROM devices.

The MBM29DL400TC/BC are programmed by executing the program command sequence. This will invoke the Embedded Program Algorithm which is an internal algorithm that automatically times the program pulse widths and verifies proper cell margin. Typically, each sector can be programmed and verified in about 0.5 seconds. Erase is accomplished by executing the erase command sequence. This will invoke the Embedded Erase Algorithm which is an internal algorithm that automatically preprograms the array if it is not already programmed before executing the erase operation. During erase, the devices automatically time the erase pulse widths and verify proper cell margin.

A sector is typically erased and verified in 1.0 second. (If already completely preprogrammed.)

The devices also feature a sector erase architecture. The sector mode allows each sector to be erased and reprogrammed without affecting other sectors. The MBM29DL400TC/BC are erased when shipped from the factory.

The devices feature single 3.0 V power supply operation for both read and write functions. Internally generated and regulated voltages are provided for the program and erase operations. A low  $V_{CC}$  detector automatically inhibits write operations on the loss of power. The end of program or erase is detected by  $\overline{Data}$  Polling of  $DQ_7$ , by the Toggle Bit feature on  $DQ_6$ , or the  $RY/\overline{BY}$  output pin. Once the end of a program or erase cycle has been completed, the devices internally reset to the read mode.

Fujitsu's Flash technology combines years of EPROM and E<sup>2</sup>PROM experience to produce the highest levels of quality, reliability, and cost effectiveness. The MBM29DL400TC/BC memories electrically erase the entire chip or all bits within a sector simultaneously via Fowler-Nordhiem tunneling. The bytes/words are programmed one byte/word at a time using the EPROM programming mechanism of hot electron injection.

## ■ FLEXIBLE SECTOR-ERASE ARCHITECTURE

- Two 16K bytes, four 8K bytes, two 32K bytes, and six 64K bytes
- Individual-sector, multiple-sector, or bulk-erase capability
- Individual or multiple-sector protection is user definable.

		(X8)	(X16)
bank 1	16K byte/8K word	7FFFFH	3FFFFH
	32K byte/16K word	7C000H	3E000H
	8K byte/4K word	74000H	3A000H
	8K byte/4K word	72000H	39000H
	8K byte/4K word	70000H	38000H
	8K byte/4K word	6E000H	37000H
	8K byte/4K word	6C000H	36000H
	32K byte/16K word	64000H	32000H
bank 2	16K byte/8K word	60000H	30000H
	64K byte/32K word	50000H	28000H
	64K byte/32K word	40000H	20000H
	64K byte/32K word	30000H	18000H
	64K byte/32K word	20000H	10000H
	64K byte/32K word	10000H	08000H
	64K byte/32K word	00000H	00000H

**MBM29DL400TC Sector Architecture**

		(X8)	(X16)
bank 2	64K byte/32K word	7FFFFH	3FFFFH
	64K byte/32K word	70000H	38000H
	64K byte/32K word	60000H	30000H
	64K byte/32K word	50000H	28000H
	64K byte/32K word	40000H	20000H
	64K byte/32K word	30000H	18000H
	64K byte/32K word	20000H	10000H
	16K byte/8K word	1C000H	0C000H
bank 1	32K byte/16K word	14000H	0A000H
	8K byte/4K word	12000H	09000H
	8K byte/4K word	10000H	08000H
	8K byte/4K word	0E000H	07000H
	8K byte/4K word	0C000H	06000H
	32K byte/16K word	04000H	02000H
	16K byte/8K word	00000H	00000H

**MBM29DL400BC Sector Architecture**

# MBM29DL400TC-55/-70/-90/-12/MBM29DL400BC-55/-70/-90/-12

## ■ PRODUCT LINE UP

Part No.		MBM29DL400TC/MBM29DL400BC			
Ordering Part No.	$V_{CC} = 3.3\text{ V}$ $\begin{matrix} +0.3\text{ V} \\ -0.3\text{ V} \end{matrix}$	-55	-70	—	—
	$V_{CC} = 3.0\text{ V}$ $\begin{matrix} +0.6\text{ V} \\ -0.3\text{ V} \end{matrix}$	—	—	-90	-12
Max. Address Access Time (ns)		55	70	90	120
Max. $\overline{CE}$ Access Time (ns)		55	70	90	120
Max. $\overline{OE}$ Access Time (ns)		30	30	35	50

## ■ BLOCK DIAGRAM

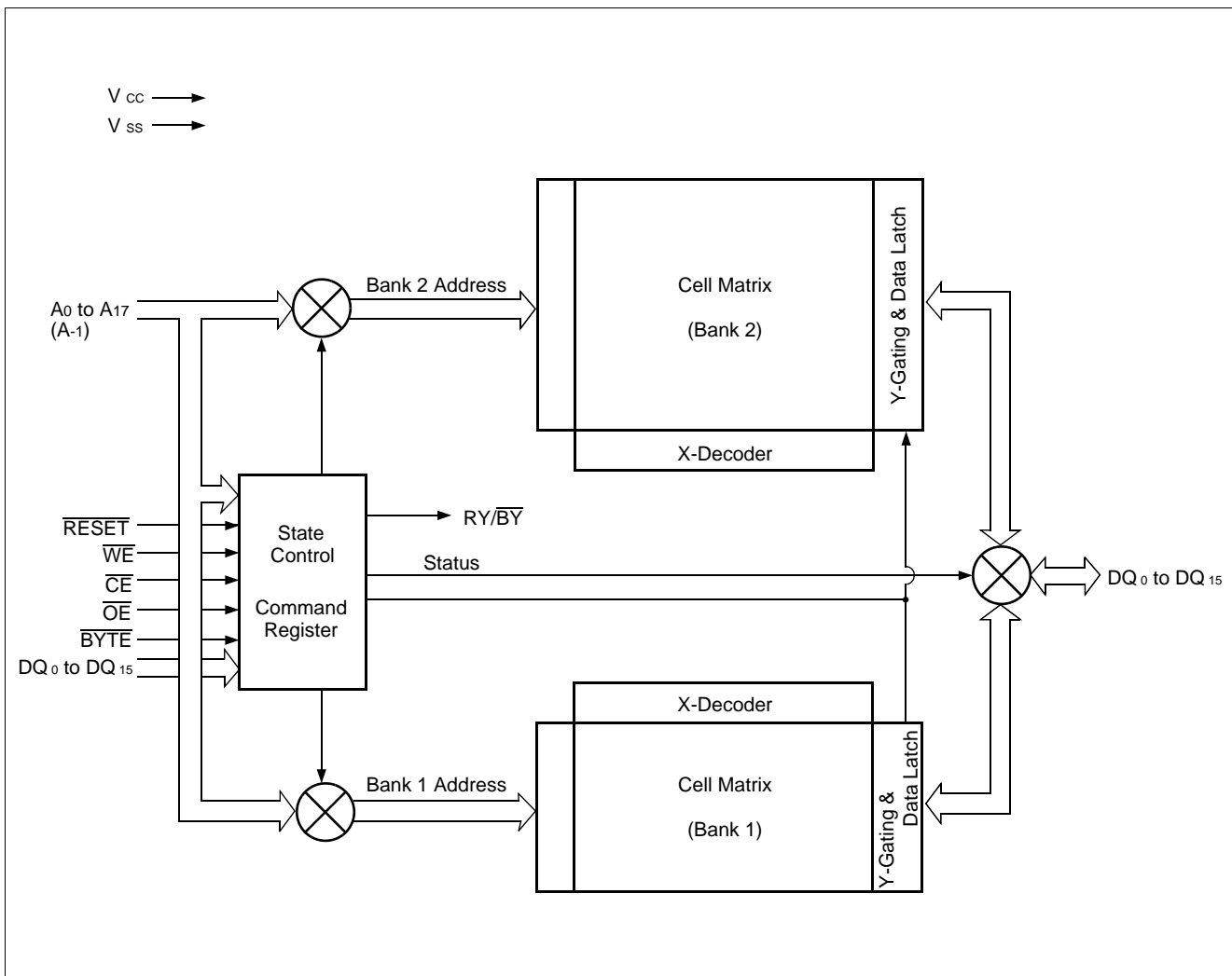

# MBM29DL400TC-55/-70/-90/-12/MBM29DL400BC-55/-70/-90/-12

## CONNECTION DIAGRAMS

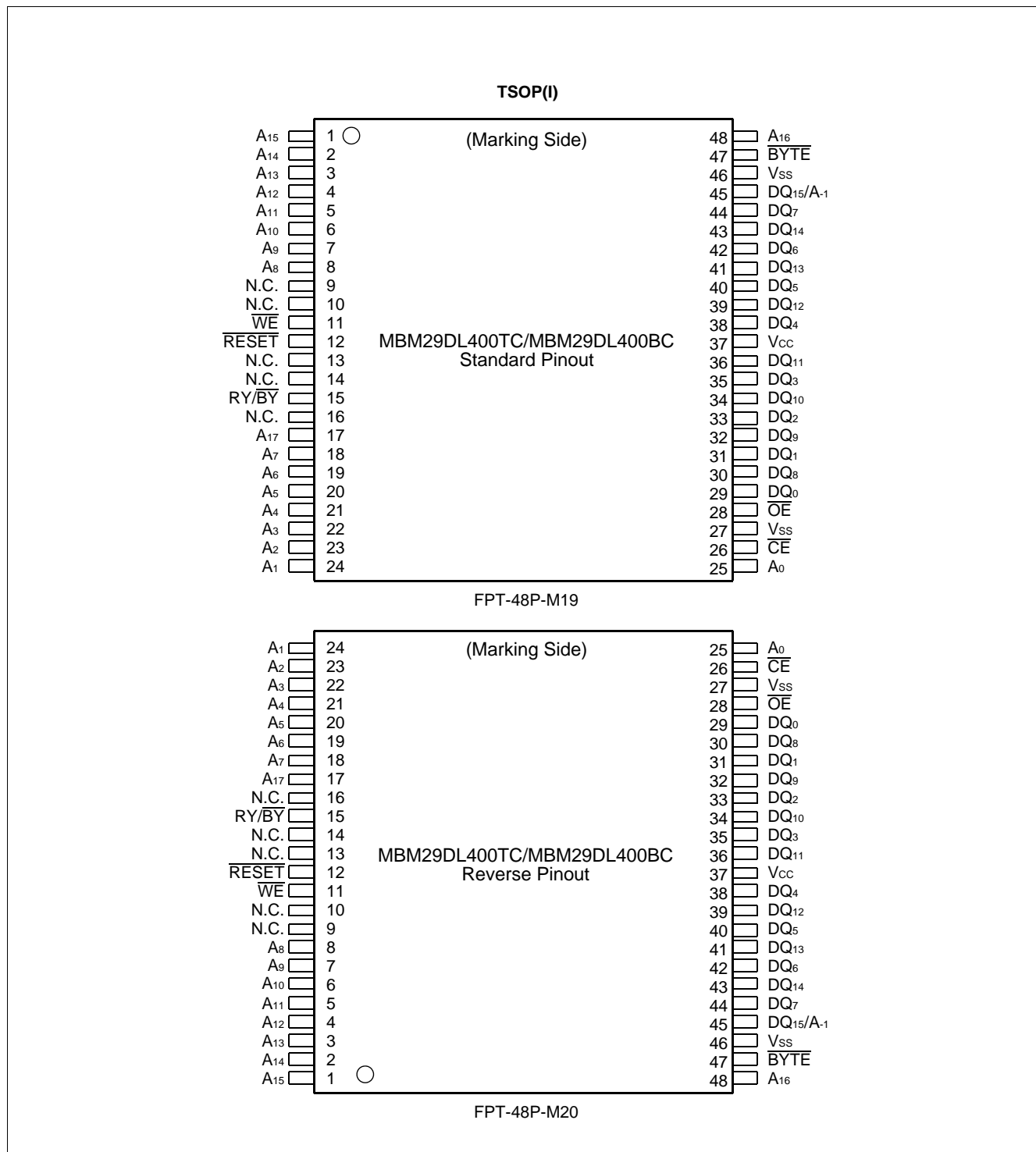

## ■ LOGIC SYMBOL

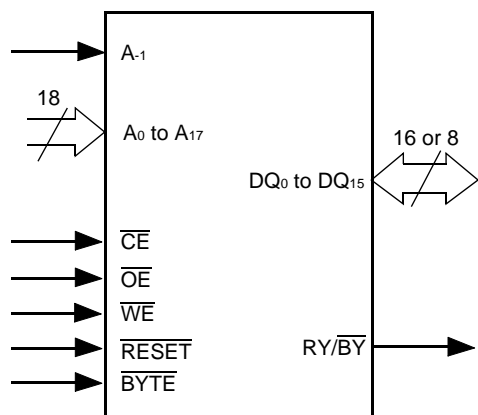



Table 1 MBM29DL400TC/BC Pin Configuration

Pin	Function
A-1, A <sub>0</sub> to A <sub>17</sub>	Address Inputs
DQ <sub>0</sub> to DQ <sub>15</sub>	Data Inputs/Outputs
$\overline{CE}$	Chip Enable
$\overline{OE}$	Output Enable
$\overline{WE}$	Write Enable
RY/ $\overline{BY}$	Ready/Busy Output
$\overline{RESET}$	Hardware Reset Pin/Temporary Sector Unprotection
$\overline{BYTE}$	Selects 8-bit or 16-bit mode
N.C.	No Internal Connection
V <sub>SS</sub>	Device Ground
V <sub>CC</sub>	Device Power Supply

# MBM29DL400TC-55/-70/-90/-12/MBM29DL400BC-55/-70/-90/-12

**Table 2 MBM29DL400TC/BC User Bus Operations ( $\overline{\text{BYTE}} = V_{IH}$ )**

Operation	$\overline{\text{CE}}$	$\overline{\text{OE}}$	$\overline{\text{WE}}$	A <sub>0</sub>	A <sub>1</sub>	A <sub>6</sub>	A <sub>9</sub>	DQ <sub>0</sub> to DQ <sub>15</sub>	$\overline{\text{RESET}}$
Auto-Select Manufacturer Code (1)	L	L	H	L	L	L	V <sub>ID</sub>	Code	H
Auto-Select Device Code (1)	L	L	H	H	L	L	V <sub>ID</sub>	Code	H
Read (3)	L	L	H	A <sub>0</sub>	A <sub>1</sub>	A <sub>6</sub>	A <sub>9</sub>	D <sub>OUT</sub>	H
Standby	H	X	X	X	X	X	X	HIGH-Z	H
Output Disable	L	H	H	X	X	X	X	HIGH-Z	H
Write (Program/Erase)	L	H	L	A <sub>0</sub>	A <sub>1</sub>	A <sub>6</sub>	A <sub>9</sub>	D <sub>IN</sub>	H
Enable Sector Protection (2), (4)	L	V <sub>ID</sub>		L	H	L	V <sub>ID</sub>	X	H
Verify Sector Protection (2), (4)	L	L	H	L	H	L	V <sub>ID</sub>	Code	H
Temporary Sector Unprotection (5)	X	X	X	X	X	X	X	X	V <sub>ID</sub>
Reset (Hardware)/Standby	X	X	X	X	X	X	X	HIGH-Z	L

**Table 3 MBM29DL400TC/BC User Bus Operations ( $\overline{\text{BYTE}} = V_{IL}$ )**

Operation	$\overline{\text{CE}}$	$\overline{\text{OE}}$	$\overline{\text{WE}}$	DQ <sub>15</sub> / A <sub>-1</sub>	A <sub>0</sub>	A <sub>1</sub>	A <sub>6</sub>	A <sub>9</sub>	DQ <sub>0</sub> to DQ <sub>7</sub>	$\overline{\text{RESET}}$
Auto-Select Manufacturer Code (1)	L	L	H	L	L	L	L	V <sub>ID</sub>	Code	H
Auto-Select Device Code (1)	L	L	H	L	H	L	L	V <sub>ID</sub>	Code	H
Read (3)	L	L	H	A <sub>-1</sub>	A <sub>0</sub>	A <sub>1</sub>	A <sub>6</sub>	A <sub>9</sub>	D <sub>OUT</sub>	H
Standby	H	X	X	X	X	X	X	X	HIGH-Z	H
Output Disable	L	H	H	X	X	X	X	X	HIGH-Z	H
Write (Program/Erase)	L	H	L	A <sub>-1</sub>	A <sub>0</sub>	A <sub>1</sub>	A <sub>6</sub>	A <sub>9</sub>	D <sub>IN</sub>	H
Enable Sector Protection (2), (4)	L	V <sub>ID</sub>		L	L	H	L	V <sub>ID</sub>	X	H
Verify Sector Protection (2), (4)	L	L	H	L	L	H	L	V <sub>ID</sub>	Code	H
Temporary Sector Unprotection (5)	X	X	X	X	X	X	X	X	X	V <sub>ID</sub>
Reset (Hardware)/Standby	X	X	X	X	X	X	X	X	HIGH-Z	L

**Legend:** L = V<sub>IL</sub>, H = V<sub>IH</sub>, X = V<sub>IL</sub> or V<sub>IH</sub>,  = Pulse input. See DC Characteristics for voltage levels.

- Notes:**
1. Manufacturer and device codes may also be accessed via a command register write sequence. See Table 8.
  2. Refer to the section on Sector Protection.
  3.  $\overline{\text{WE}}$  can be V<sub>IL</sub> if  $\overline{\text{OE}}$  is V<sub>IL</sub>,  $\overline{\text{OE}}$  at V<sub>IH</sub> initiates the write operations.
  4. V<sub>CC</sub> = 3.3 V ± 10%
  5. It is also used for the extended sector protection.



# MBM29DL400TC-55/-70/-90/-12/MBM29DL400BC-55/-70/-90/-12

## ■ ORDERING INFORMATION

### Standard Products

Fujitsu standard products are available in several packages. The order number is formed by a combination of:

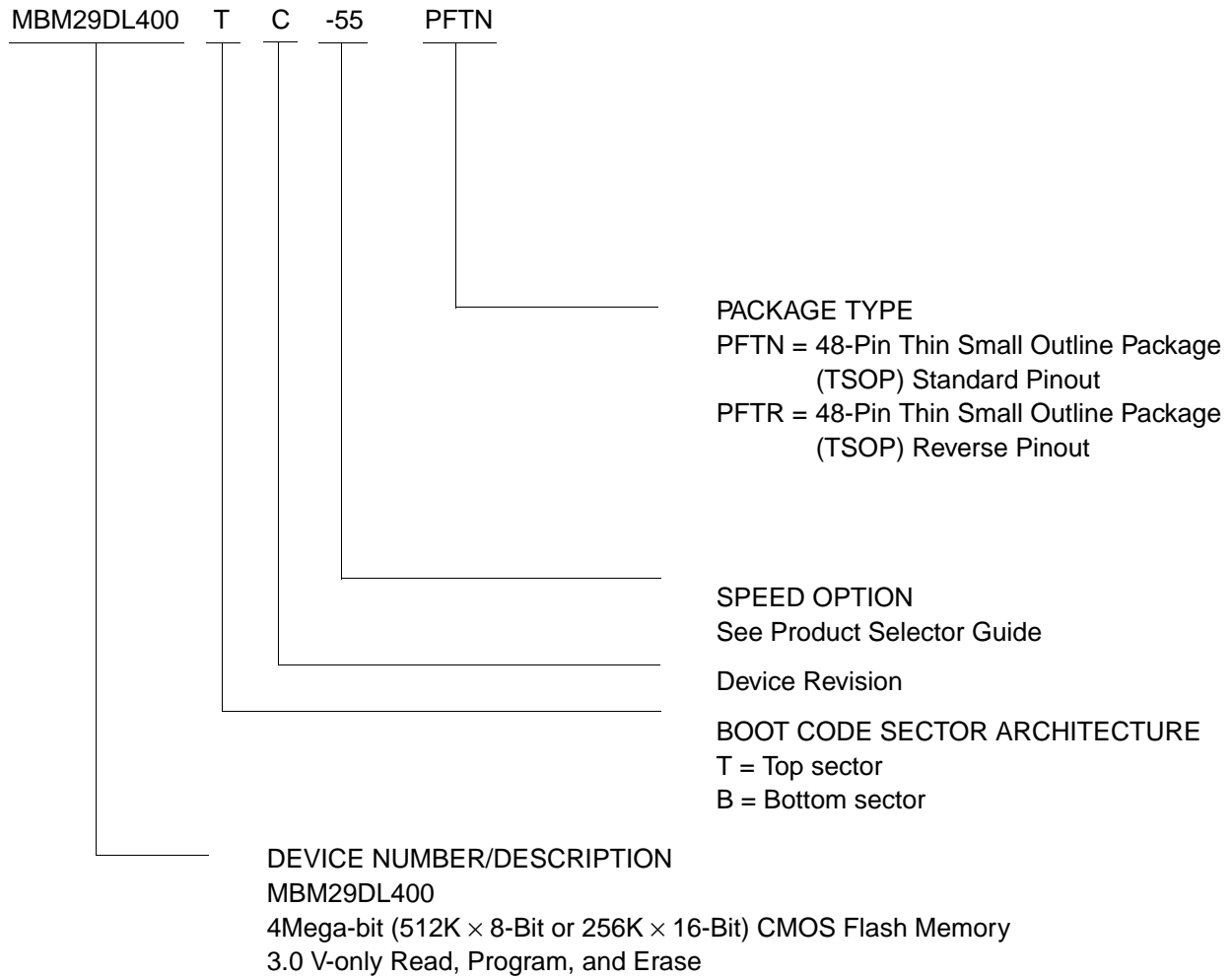

## ■ FUNCTIONAL DESCRIPTION

### Simultaneous Operation

MBM29DL400TC/BC have feature, which is capability of reading data from one bank of memory while a program or erase operation is in progress in the other bank of memory (simultaneous operation), in addition to the conventional features (read, program, erase, erase-suspend read, and erase-suspend program). The bank selection can be selected by bank address ( $A_{16}$ ,  $A_{17}$ ) with zero latency.

The MBM29DL400TC/BC have two banks which contain Bank 1 (16KB, 32KB, 8KB, 8KB, 8KB, 8KB, 32KB, and 16KB) and Bank 2 (64KB × six sectors).

The simultaneous operation can not execute multi-function mode in the same bank. Table 4 shows combination to be possible for simultaneous operation.

**Table 4 Simultaneous Operation**

Case	Bank 1 Status	Bank 2 Status
1	Read mode	Read mode
2	Read mode	Autoselect mode
3	Read mode	Program mode
4	Read mode	Erase mode *
5	Autoselect mode	Read mode
6	Program mode	Read mode
7	Erase mode *	Read mode

\*: An erase operation may also be suspended to read from or program to a sector not being erased.

### Read Mode

The MBM29DL400TC/BC have two control functions which must be satisfied in order to obtain data at the outputs.  $\overline{CE}$  is the power control and should be used for a device selection.  $\overline{OE}$  is the output control and should be used to gate data to the output pins if a device is selected.

Address access time ( $t_{ACC}$ ) is equal to the delay from stable addresses to valid output data. The chip enable access time ( $t_{CE}$ ) is the delay from stable addresses and stable  $\overline{CE}$  to valid data at the output pins. The output enable access time is the delay from the falling edge of  $\overline{OE}$  to valid data at the output pins. (Assuming the addresses have been stable for at least  $t_{ACC-tOE}$  time.) When reading out a data without changing addresses after power-up, it is necessary to input hardware reset or to change  $\overline{CE}$  pin from “H” or “L”

### Standby Mode

There are two ways to implement the standby mode on the MBM29DL400TC/BC devices, one using both the  $\overline{CE}$  and  $\overline{RESET}$  pins; the other via the  $\overline{RESET}$  pin only.

When using both pins, a CMOS standby mode is achieved with  $\overline{CE}$  and  $\overline{RESET}$  inputs both held at  $V_{CC} \pm 0.3$  V. Under this condition the current consumed is less than 5  $\mu$ A max. During Embedded Algorithm operation,  $V_{CC}$  active current ( $I_{CC2}$ ) is required even  $\overline{CE} = \text{“H”}$ . The device can be read with standard access time ( $t_{CE}$ ) from either of these standby modes.

When using the  $\overline{RESET}$  pin only, a CMOS standby mode is achieved with  $\overline{RESET}$  input held at  $V_{SS} \pm 0.3$  V ( $\overline{CE} = \text{“H”}$  or “L”). Under this condition the current is consumed is less than 5  $\mu$ A max. Once the  $\overline{RESET}$  pin is taken high, the device requires  $t_{RH}$  of wake up time before outputs are valid for read access.

In the standby mode the outputs are in the high impedance state, independent of the  $\overline{OE}$  input.

## Automatic Sleep Mode

There is a function called automatic sleep mode to restrain power consumption during read-out of MBM29DL400TC/BC data. This mode can be used effectively with an application requested low power consumption such as handy terminals.

To activate this mode, MBM29DL400TC/BC automatically switch themselves to low power mode when MBM29DL400TC/BC addresses remain stably during access time of 150 ns. It is not necessary to control  $\overline{CE}$ ,  $\overline{WE}$ , and  $\overline{OE}$  on the mode. Under the mode, the current consumed is typically 1  $\mu$ A (CMOS Level).

During simultaneous operation,  $V_{CC}$  active current ( $I_{CC2}$ ) is required.

Since the data are latched during this mode, the data are read-out continuously. If the addresses are changed, the mode is canceled automatically and MBM29DL400TC/BC read-out the data for changed addresses.

## Output Disable

With the  $\overline{OE}$  input at a logic high level ( $V_{IH}$ ), output from the devices are disabled. This will cause the output pins to be in a high impedance state.

## Autoselect

The autoselect mode allows the reading out of a binary code from the devices and will identify its manufacturer and type. This mode is intended for use by programming equipment for the purpose of automatically matching the devices to be programmed with its corresponding programming algorithm. This mode is functional over the entire temperature range of the devices.

To activate this mode, the programming equipment must force  $V_{ID}$  (11.5 V to 12.5 V) on address pin  $A_9$ . Two identifier bytes may then be sequenced from the devices outputs by toggling address  $A_0$  from  $V_{IL}$  to  $V_{IH}$ . All addresses are DON'T CARES except  $A_0$ ,  $A_1$ , and  $A_6$  ( $A_{-1}$ ). (See Tables 2 and 3.)

The manufacturer and device codes may also be read via the command register, for instances when the MBM29DL400TC/BC are erased or programmed in a system without access to high voltage on the  $A_9$  pin. The command sequence is illustrated in Table 8. (Refer to Autoselect Command section.)

Word 0 ( $A_0 = V_{IL}$ ) represents the manufacturer's code (Fujitsu = 04H) and word 1 ( $A_0 = V_{IH}$ ) represents the device identifier code (MBM29DL400TC = 0CH and MBM29DL400BC = 0FH for  $\times 8$  mode; MBM29DL400TC = 220CH and MBM29DL400BC = 220FH for  $\times 16$  mode). These two bytes/words are given in the tables 5.1 and 5.2. All identifiers for manufactures and device will exhibit odd parity with  $DQ_7$  defined as the parity bit. In order to read the proper device codes when executing the autoselect,  $A_1$  must be  $V_{IL}$ . (See Tables 5.1 and 5.2.)

In case of applying  $V_{ID}$  on  $A_9$ , since both Bank 1 and Bank 2 enters Autoselect mode, the simultaneous operation can not be executed.

# MBM29DL400TC-55/-70/-90/-12/MBM29DL400BC-55/-70/-90/-12

**Table 5.1 MBM29DL400TC/BC Sector Protection Verify Autoselect Codes**

Type		A <sub>12</sub> to A <sub>17</sub>	A <sub>6</sub>	A <sub>1</sub>	A <sub>0</sub>	A <sub>-1</sub> <sup>*1</sup>	Code (HEX)
Manufacturer's Code		X	V <sub>IL</sub>	V <sub>IL</sub>	V <sub>IL</sub>	V <sub>IL</sub>	04H
Device Code	MBM29DL400TC	Byte	X	V <sub>IL</sub>	V <sub>IL</sub>	V <sub>IL</sub>	0CH
		Word				X	220CH
	MBM29DL400BC	Byte	X	V <sub>IL</sub>	V <sub>IL</sub>	V <sub>IL</sub>	0FH
		Word				X	220FH
Sector Protection		Sector Addresses	V <sub>IL</sub>	V <sub>IH</sub>	V <sub>IL</sub>	V <sub>IL</sub>	01H <sup>*2</sup>

\*1: A<sub>-1</sub> is for Byte mode.

\*2: Outputs 01H at protected sector addresses and outputs 00H at unprotected sector addresses.

**Table 5.2 Expanded Autoselect Code Table**

Type		Code	DQ <sub>15</sub>	DQ <sub>14</sub>	DQ <sub>13</sub>	DQ <sub>12</sub>	DQ <sub>11</sub>	DQ <sub>10</sub>	DQ <sub>9</sub>	DQ <sub>8</sub>	DQ <sub>7</sub>	DQ <sub>6</sub>	DQ <sub>5</sub>	DQ <sub>4</sub>	DQ <sub>3</sub>	DQ <sub>2</sub>	DQ <sub>1</sub>	DQ <sub>0</sub>
Manufacturer's Code		04H	A <sub>-1</sub> /0	0	0	0	0	0	0	0	0	0	0	0	0	1	0	0
Device Code	MBM29DL400TC	(B)	0CH	A <sub>-1</sub>	HI-Z	HI-Z	HI-Z	HI-Z	HI-Z	HI-Z	0	0	0	0	1	1	0	0
		(W)	220CH	0	0	1	0	0	0	1	0	0	0	0	0	1	1	0
	MBM29DL400BC	(B)	0FH	A <sub>-1</sub>	HI-Z	HI-Z	HI-Z	HI-Z	HI-Z	HI-Z	0	0	0	0	1	1	1	1
		(W)	220FH	0	0	1	0	0	0	1	0	0	0	0	0	1	1	1
Sector Protection		01H	A <sub>-1</sub> /0	0	0	0	0	0	0	0	0	0	0	0	0	0	0	1

(B): Byte mode

(W): Word mode

## Write

Device erasure and programming are accomplished via the command register. The contents of the register serve as inputs to the internal state machine. The state machine outputs dictate the function of the device.

The command register itself does not occupy any addressable memory location. The register is a latch used to store the commands, along with the address and data information needed to execute the command. The command register is written by bringing  $\overline{WE}$  to  $V_{IL}$ , while  $\overline{CE}$  is at  $V_{IL}$  and  $\overline{OE}$  is at  $V_{IH}$ . Addresses are latched on the falling edge of  $\overline{WE}$  or  $\overline{CE}$ , whichever happens later; while data is latched on the rising edge of  $\overline{WE}$  or  $\overline{CE}$ , whichever happens first. Standard microprocessor write timings are used.

Refer to AC Write Characteristics and the Erase/Programming Waveforms for specific timing parameters.

## Sector Protection

The MBM29DL400TC/BC feature hardware sector protection. This feature will disable both program and erase operations in any number of sectors (0 through 13). The sector protection feature is enabled using programming equipment at the user's site. The devices are shipped with all sectors unprotected. Alternatively, Fujitsu may program and protect sectors in the factory prior to shipping the device.

To activate this mode, the programming equipment must force  $V_{ID}$  on address pin  $A_9$  and control pin  $\overline{OE}$ , (suggest  $V_{ID} = 11.5\text{ V}$ ),  $\overline{CE} = V_{IL}$ , and  $A_0 = A_6 = V_{IL}$ ,  $A_1 = V_{IH}$ . The sector addresses ( $A_{17}$ ,  $A_{16}$ ,  $A_{15}$ ,  $A_{14}$ ,  $A_{13}$ , and  $A_{12}$ ) should be set to the sector to be protected. Tables 6 and 7 define the sector address for each of the fourteen (14) individual sectors. Programming of the protection circuitry begins on the falling edge of the  $\overline{WE}$  pulse and is terminated with the rising edge of the same. Sector addresses must be held constant during the  $\overline{WE}$  pulse. See Figures 16 and 25 for sector protection waveforms and algorithm.

To verify programming of the protection circuitry, the programming equipment must force  $V_{ID}$  on address pin  $A_9$  with  $\overline{CE}$  and  $\overline{OE}$  at  $V_{IL}$  and  $\overline{WE}$  at  $V_{IH}$ . Scanning the sector addresses ( $A_{17}$ ,  $A_{16}$ ,  $A_{15}$ ,  $A_{14}$ ,  $A_{13}$ , and  $A_{12}$ ) while  $(A_6, A_1, A_0) = (0, 1, 0)$  will produce a logical "1" code at device output  $DQ_0$  for a protected sector. Otherwise the devices will read 00H for unprotected sector. In this mode, the lower order addresses, except for  $A_0$ ,  $A_1$ , and  $A_6$  are DON'T CARES. Address locations with  $A_1 = V_{IL}$  are reserved for Autoselect manufacturer and device codes.  $A_{-1}$  requires to apply to  $V_{IL}$  on byte mode.

It is also possible to determine if a sector is protected in the system by writing an Autoselect command. Performing a read operation at the address location XX02H, where the higher order addresses ( $A_{17}$ ,  $A_{16}$ ,  $A_{15}$ ,  $A_{14}$ ,  $A_{13}$ , and  $A_{12}$ ) are the desired sector address will produce a logical "1" at  $DQ_0$  for a protected sector. See Tables 5.1 and 5.2 for Autoselect codes.

## Temporary Sector Unprotection

This feature allows temporary unprotection of previously protected sectors of the MBM29DL400TC/BC devices in order to change data. The Sector Unprotection mode is activated by setting the  $\overline{RESET}$  pin to high voltage (12 V). During this mode, formerly protected sectors can be programmed or erased by selecting the sector addresses. Once the 12 V is taken away from the  $\overline{RESET}$  pin, all the previously protected sectors will be protected again. See Figures 17 and 26.

## RESET

### Hardware Reset

The MBM29DL400TC/BC devices may be reset by driving the  $\overline{\text{RESET}}$  pin to  $V_{IL}$ . The  $\overline{\text{RESET}}$  pin has a pulse requirement and has to be kept low ( $V_{IL}$ ) for at least 500 ns in order to properly reset the internal state machine. Any operation in the process of being executed will be terminated and the internal state machine will be reset to the read mode 20  $\mu\text{s}$  after the  $\overline{\text{RESET}}$  pin is driven low. Furthermore, once the  $\overline{\text{RESET}}$  pin goes high, the devices require an additional  $t_{RH}$  before it will allow read access. When the  $\overline{\text{RESET}}$  pin is low, the devices will be in the standby mode for the duration of the pulse and all the data output pins will be tri-stated. If a hardware reset occurs during a program or erase operation, the data at that particular location will be corrupted. Please note that the  $\text{RY}/\overline{\text{BY}}$  output signal should be ignored during the  $\overline{\text{RESET}}$  pulse. See Figure 12 for the timing diagram. Refer to Temporary Sector Unprotection for additional functionality.

# MBM29DL400TC-55/-70/-90/-12/MBM29DL400BC-55/-70/-90/-12

**Table 6 Sector Address Tables (MBM29DL400TC)**

Bank	Sector	Sector Address						Sector Size (K bytes/ K words)	(X 8) Address Range	(X 16) Address Range
		Bank Address		A <sub>15</sub>	A <sub>14</sub>	A <sub>13</sub>	A <sub>12</sub>			
		A <sub>17</sub>	A <sub>16</sub>							
Bank 2	SA0	0	0	0	X	X	X	64/32	00000H to 0FFFFH	00000H to 07FFFH
	SA1	0	0	1	X	X	X	64/32	10000H to 1FFFFH	08000H to 0FFFFH
	SA2	0	1	0	X	X	X	64/32	20000H to 2FFFFH	10000H to 17FFFH
	SA3	0	1	1	X	X	X	64/32	30000H to 3FFFFH	18000H to 1FFFFH
	SA4	1	0	0	X	X	X	64/32	40000H to 4FFFFH	20000H to 27FFFH
	SA5	1	0	1	X	X	X	64/32	50000H to 5FFFFH	28000H to 2FFFFH
Bank 1	SA6	1	1	0	0	0	X	16/8	60000H to 63FFFH	30000H to 31FFFH
	SA7	1	1	0	0	1	X	32/16	64000H to 67FFFH 68000H to 6BFFFH	32000H to 33FFFH 34000H to 35FFFH
					1	0				
	SA8	1	1	0	1	1	0	8/4	6C000H to 6DFFFH	36000H to 36FFFH
	SA9	1	1	0	1	1	1	8/4	6E000H to 6FFFFH	37000H to 37FFFH
	SA10	1	1	1	0	0	0	8/4	70000H to 71FFFH	38000H to 38FFFH
	SA11	1	1	1	0	0	1	8/4	72000H to 73FFFH	39000H to 39FFFH
	SA12	1	1	1	0	1	X	32/16	74000H to 77FFFH 78000H to 7BFFFH	3A000H to 3BFFFH 3C000H to 3DFFFH
1					0					
SA13	1	1	1	1	1	X	16/8	7C000H to 7FFFFH	3E000H to 3FFFFH	

**Note:** The address range is A<sub>17</sub>: A<sub>-1</sub> if in byte mode ( $\overline{\text{BYTE}} = V_{IL}$ ). The address range is A<sub>17</sub>: A<sub>0</sub> if in word mode ( $\text{BYTE} = V_{IH}$ ).

**Table 7 Sector Address Tables (MBM29DL400BC)**

Bank	Sector	Sector Address						Sector Size (Kbytes/ Kwords)	Address Range (×8)	Address Range (×16)
		Bank Address		A <sub>15</sub>	A <sub>14</sub>	A <sub>13</sub>	A <sub>12</sub>			
		A <sub>17</sub>	A <sub>16</sub>							
Bank 2	SA13	1	1	1	X	X	X	64/32	70000H to 7FFFFH	38000H to 3FFFFH
	SA12	1	1	0	X	X	X	64/32	60000H to 6FFFFH	30000H to 37FFFH
	SA11	1	0	1	X	X	X	64/32	50000H to 5FFFFH	28000H to 2FFFFH
	SA10	1	0	0	X	X	X	64/32	40000H to 4FFFFH	20000H to 27FFFH
	SA9	0	1	1	X	X	X	64/32	30000H to 3FFFFH	18000H to 1FFFFH
	SA8	0	1	0	X	X	X	64/32	20000H to 2FFFFH	10000H to 17FFFH
Bank 1	SA7	0	0	1	1	1	X	16/8	1C000H to 1FFFFH	0E000H to 0FFFFH
	SA6	0	0	1	1	0	X	32/16	14000H to 17FFFH, 18000H to 1BFFFH	0A000H to 0BFFFH, 0C000H to 0DFFFH
					0	1	X			
	SA5	0	0	1	0	0	1	8/4	12000H to 13FFFH	09000H to 09FFFH
	SA4	0	0	1	0	0	0	8/4	10000H to 11FFFH	08000H to 08FFFH
	SA3	0	0	0	1	1	1	8/4	0E000H to 0FFFFH	07000H to 07FFFH
	SA2	0	0	0	1	1	0	8/4	0C000H to 0DFFFH	06000H to 06FFFH
	SA1	0	0	0	1	0	X	32/16	08000H to 0BFFFH, 04000H to 07FFFH	04000H to 05FFFH, 02000H to 03FFFH
0					1	X				
SA0	0	0	0	0	0	X	16/8	00000H to 03FFFH	00000H to 01FFFH	

**Note:** The address range is A<sub>17</sub>: A<sub>-1</sub> if in byte mode ( $\overline{\text{BYTE}} = V_{IL}$ ). The address range is A<sub>17</sub>: A<sub>0</sub> if in word mode ( $\overline{\text{BYTE}} = V_{IH}$ ).



# MBM29DL400TC-55/-70/-90/-12/MBM29DL400BC-55/-70/-90/-12

**Table 8 MBM29DL400TC/BC Command Definitions**

Command Sequence		Bus Write Cycles Req'd	First Bus Write Cycle		Second Bus Write Cycle		Third Bus Write Cycle		Fourth Bus Read/Write Cycle		Fifth Bus Write Cycle		Sixth Bus Write Cycle	
			Addr.	Data	Addr.	Data	Addr.	Data	Addr.	Data	Addr.	Data	Addr.	Data
Read/Reset	Word	1	XXXH	F0H	—	—	—	—	—	—	—	—	—	—
	Byte													
Read/Reset	Word	3	555H	AAH	2AAH	55H	555H	F0H	RA	RD	—	—	—	—
	Byte		AAAH		555H		AAAH							
Autoselect	Word	3	555H	AAH	2AAH	55H	(BA) 555H	90H	—	—	—	—	—	—
	Byte		AAAH		555H		(BA) AAAH							
Program	Word	4	555H	AAH	2AAH	55H	555H	A0H	PA	PD	—	—	—	—
	Byte		AAAH		555H		AAAH							
Chip Erase	Word	6	555H	AAH	2AAH	55H	555H	80H	555H	AAH	2AAH	55H	555H	10H
	Byte		AAAH		555H		AAAH		555H		AAAH			
Sector Erase	Word	6	555H	AAH	2AAH	55H	555H	80H	555H	AAH	2AAH	55H	SA	30H
	Byte		AAAH		555H		AAAH		555H		AAAH			
Erase Suspend		1	BA	B0H	—	—	—	—	—	—	—	—	—	—
Erase Resume		1	BA	30H	—	—	—	—	—	—	—	—	—	—
Set to Fast Mode	Word	3	555H	AAH	2AAH	55H	555H	20H	—	—	—	—	—	—
	Byte		AAAH		555H		AAAH							
Fast Program *	Word	2	XXXH	A0H	PA	PD	—	—	—	—	—	—	—	—
	Byte		XXXH		—									
Reset from Fast Mode *	Word	2	BA	90H	XXXH	F0H	—	—	—	—	—	—	—	—
	Byte		BA		XXXH									
Extended Sector Protect	Word	4	XXXH	60H	SPA	60H	SPA	40H	SPA	SD	—	—	—	—
	Byte		—		—		—							

- Notes:**
1. Address bits A<sub>11</sub> to A<sub>17</sub> = X = "H" or "L" for all address commands except or Program Address (PA), Sector Address (SA), and Bank Address (BA).
  2. Bus operations are defined in Tables 2 and 3.
  3. RA = Address of the memory location to be read  
PA = Address of the memory location to be programmed  
Addresses are latched on the falling edge of the write pulse.  
SA = Address of the sector to be erased. The combination of A<sub>17</sub>, A<sub>16</sub>, A<sub>15</sub>, A<sub>14</sub>, A<sub>13</sub>, and A<sub>12</sub> will uniquely select any sector.  
BA = Bank Address (A<sub>16</sub> to A<sub>17</sub>)
  4. RD = Data read from location RA during read operation.  
PD = Data to be programmed at location PA. Data is latched on the falling edge of write pulse.
  5. SPA = Sector address to be protected. Set sector address (SA) and (A<sub>6</sub>, A<sub>1</sub>, A<sub>0</sub>) = (0, 1, 0).  
SD = Sector protection verify data. Output 01H at protected sector addresses and output 00H at unprotected sector addresses.
- \* : This command is valid while Fast Mode.
6. The system should generate the following address patterns:  
Word Mode: 555H or 2AAH to addresses A<sub>0</sub> to A<sub>10</sub>  
Byte Mode: AAH or 555H to addresses A<sub>-1</sub> and A<sub>0</sub> to A<sub>10</sub>
  7. Both Read/Reset commands are functionally equivalent, resetting the device to the read mode.

## Command Definitions

Device operations are selected by writing specific address and data sequences into the command register. Writing incorrect address and data values or writing them in the improper sequence will reset the devices to the read mode. Some commands are required Bank Address (BA) input. When command sequences are inputted to bank being read, the commands have priority than reading. Table 8 defines the valid register command sequences. Note that the Erase Suspend (B0H) and Erase Resume (30H) commands are valid only while the Sector Erase operation is in progress. Moreover both Read/Reset commands are functionally equivalent, resetting the device to the read mode. Please note that commands are always written at DQ<sub>0</sub> to DQ<sub>7</sub> and DQ<sub>8</sub> to DQ<sub>15</sub> bits are ignored.

## Read/Reset Command

In order to return from Autoselect mode or Exceeded Timing Limits (DQ<sub>5</sub> = 1) to Read/Reset mode, the Read/Reset operation is initiated by writing the Read/Reset command sequence into the command register. Microprocessor read cycles retrieve array data from the memory. The devices remain enabled for reads until the command register contents are altered.

The devices will automatically power-up in the Read/Reset state. In this case, a command sequence is not required to read data. Standard microprocessor read cycles will retrieve array data. This default value ensures that no spurious alteration of the memory content occurs during the power transition. Refer to the AC Read Characteristics and Waveforms for the specific timing parameters.

## Autoselect Command

Flash memories are intended for use in applications where the local CPU alters memory contents. As such, manufacture and device codes must be accessible while the devices reside in the target system. PROM programmers typically access the signature codes by raising A<sub>9</sub> to a high voltage. However, multiplexing high voltage onto the address lines is not generally desired system design practice.

The device contains an Autoselect command operation to supplement traditional PROM programming methodology. The operation is initiated by writing the Autoselect command sequence into the command register.

The Autoselect command sequence is initiated by first writing two unlock cycles. This is followed by a third write cycle that contains the bank address (BA) and the Autoselect command. Then the manufacture and device codes can be read from the bank, and an actual data of memory cell can be read from the another bank.

Following the command write, a read cycle from address (BA)00H retrieves the manufacture code of 04H. A read cycle from address (BA)01H for ×16((BA)02H for ×8) returns the device code (MBM29DL400TC = 0CH and MBM29DL400BC = 0FH for ×8 mode; MBM29DL400TC = 220CH and MBM29DL400BC = 220FH for ×16 mode). (See Tables 5.1 and 5.2.)

All manufacturer and device codes will exhibit odd parity with DQ<sub>7</sub> defined as the parity bit. Sector state (protection or unprotection) will be informed by address (BA)02H for ×16 ((BA)04H for ×8). Scanning the sector addresses (A<sub>17</sub>, A<sub>16</sub>, A<sub>15</sub>, A<sub>14</sub>, A<sub>13</sub>, and A<sub>12</sub>) while (A<sub>6</sub>, A<sub>1</sub>, A<sub>0</sub>) = (0, 1, 0) will produce a logical “1” at device output DQ<sub>0</sub> for a protected sector. The programming verification should be performed by verify sector protection on the protected sector. (See Tables 2 and 3.)

The manufacture and device codes can be allowed reading from selected bank. To read the manufacture and device codes and sector protection status from non-selected bank, it is necessary to write Read/Reset command sequence into the register and then Autoselect command should be written into the bank to be read.

If the software (program code) for Autoselect command is stored into the Flash memory, the device and manufacture codes should be read from the other bank where is not contain the software.

To terminate the operation, it is necessary to write the Read/Reset command sequence into the register, and also to write the Autoselect command during the operation, execute it after writing Read/Reset command sequence.

## Byte/Word Programming

The devices are programmed on a byte-by-byte (or word-by-word) basis. Programming is a four bus cycle operation. There are two “unlock” write cycles. These are followed by the program set-up command and data write cycles. Addresses are latched on the falling edge of  $\overline{CE}$  or  $\overline{WE}$ , whichever happens later and the data is latched on the rising edge of  $\overline{CE}$  or  $\overline{WE}$ , whichever happens first. The rising edge of  $\overline{CE}$  or  $\overline{WE}$  (whichever happens first) begins programming. Upon executing the Embedded Program Algorithm command sequence, the system is not required to provide further controls or timings. The device will automatically provide adequate internally generated program pulses and verify the programmed cell margin.

The system can determine the status of the program operation by using  $DQ_7$  ( $\overline{Data}$  Polling),  $DQ_6$  (Toggle Bit), or  $RY/\overline{BY}$ . The  $\overline{Data}$  Polling and Toggle Bit must be performed at the memory location which is being programmed.

The automatic programming operation is completed when the data on  $DQ_7$  is equivalent to data written to this bit at which time the devices return to the read mode and addresses are no longer latched. (See Table 9, Hardware Sequence Flags.) Therefore, the devices require that a valid address to the devices be supplied by the system at this particular instance of time. Hence,  $\overline{Data}$  Polling must be performed at the memory location which is being programmed.

Any commands written to the chip during this period will be ignored. If hardware reset occurs during the programming operation, it is impossible to guarantee the data are being written.

Programming is allowed in any sequence and across sector boundaries. Beware that a data “0” cannot be programmed back to a “1”. Attempting to do so may either hang up the device or result in an apparent success according to the data polling algorithm but a read from Read/Reset mode will show that the data is still “0”. Only erase operations can convert “0”s to “1”s.

Figure 21 illustrates the Embedded Program™ Algorithm using typical command strings and bus operations.

## Chip Erase

Chip erase is a six bus cycle operation. There are two “unlock” write cycles. These are followed by writing the “set-up” command. Two more “unlock” write cycles are then followed by the chip erase command.

Chip erase does not require the user to program the device prior to erase. Upon executing the Embedded Erase Algorithm command sequence the devices will automatically program and verify the entire memory for an all zero data pattern prior to electrical erase (Preprogram function). The system is not required to provide any controls or timings during these operations.

The system can determine the status of the erase operation by using  $DQ_7$  ( $\overline{Data}$  Polling),  $DQ_6$  (Toggle Bit), or  $RY/\overline{BY}$ . The chip erase begins on the rising edge of the last  $\overline{CE}$  or  $\overline{WE}$ , whichever happens first in the command sequence and terminates when the data on  $DQ_7$  is “1” (See Write Operation Status section.) at which time the device returns to read the mode.

Chip Erase Time; Sector Erase Time × All sectors + Chip Program Time (Preprogramming)

Figure 22 illustrates the Embedded Erase™ Algorithm using typical command strings and bus operations.

## Sector Erase

Sector erase is a six bus cycle operation. There are two “unlock” write cycles. These are followed by writing the “set-up” command. Two more “unlock” write cycles are then followed by the Sector Erase command. The sector address (any address location within the desired sector) is latched on the falling edge of  $\overline{CE}$  or  $\overline{WE}$  whichever happens later, while the command (Data=30H) is latched on the rising edge of  $\overline{CE}$  or  $\overline{WE}$  which happens first. After time-out of 50  $\mu$ s from the rising edge of the last sector erase command, the sector erase operation will begin.

Multiple sectors may be erased concurrently by writing the six bus cycle operations on Table 8. This sequence is followed with writes of the Sector Erase command to addresses in other sectors desired to be concurrently erased. The time between writes must be less than 50  $\mu$ s otherwise that command will not be accepted and erasure will start. It is recommended that processor interrupts be disabled during this time to guarantee this condition. The interrupts can be re-enabled after the last Sector Erase command is written. A time-out of 50  $\mu$ s from the rising edge of last  $\overline{CE}$  or  $\overline{WE}$  whichever happens first will initiate the execution of the Sector Erase command(s). If another falling edge of  $\overline{CE}$  or  $\overline{WE}$ , whichever happens first occurs within the 50  $\mu$ s time-out window the timer is reset. (Monitor DQ<sub>3</sub> to determine if the sector erase timer window is still open, see section DQ<sub>3</sub>, Sector Erase Timer.) Any command other than Sector Erase or Erase Suspend during this time-out period will reset the devices to the read mode, ignoring the previous command string. Resetting the devices once execution has begun will corrupt the data in the sector. In that case, restart the erase on those sectors and allow them to complete. (Refer to the Write Operation Status section for Sector Erase Timer operation.) Loading the sector erase buffer may be done in any sequence and with any number of sectors (0 to 13).

Sector erase does not require the user to program the devices prior to erase. The devices automatically program all memory locations in the sector(s) to be erased prior to electrical erase (Preprogram function). When erasing a sector or sectors the remaining unselected sectors are not affected. The system is not required to provide any controls or timings during these operations.

The system can determine the status of the erase operation by using DQ<sub>7</sub> ( $\overline{\text{Data}}$  Polling), DQ<sub>6</sub> (Toggle Bit), or RY/ $\overline{BY}$ .

The sector erase begins after the 50  $\mu$ s time out from the rising edge of  $\overline{CE}$  or  $\overline{WE}$  whichever happens first for the last sector erase command pulse and terminates when the data on DQ<sub>7</sub> is “1” (See Write Operation Status section.) at which time the devices return to the read mode.  $\overline{\text{Data}}$  polling and Toggle Bit must be performed at an address within any of the sectors being erased.

Multiple Sector Erase Time; [Sector Erase Time + Sector Program Time (Preprogramming)]  $\times$  Number of Sector Erase

In case of multiple sector erase across bank boundaries, a read from bank (read-while-erase) can not performe.

Figure 22 illustrates the Embedded Erase™ Algorithm using typical command strings and bus operations.

## Erase Suspend/Resume

The Erase Suspend command allows the user to interrupt a Sector Erase operation and then perform data reads from or programs to a sector not being erased. This command is applicable ONLY during the Sector Erase operation which includes the time-out period for sector erase. The Erase Suspend command will be ignored if written during the Chip Erase operation or Embedded Program Algorithm. Writing the Erase Suspend command (BOH) during the Sector Erase time-out results in immediate termination of the time-out period and suspension of the erase operation.

Writing the Erase Resume command (30H) resumes the erase operation. The bank addresses of sector being erasing or suspending should be set when writing the Erase Suspend or Erase Resume command.

When the Erase Suspend command is written during the Sector Erase operation, the device will take a maximum of 20  $\mu$ s to suspend the erase operation. When the devices have entered the erase-suspended mode, the RY/ $\overline{\text{BY}}$  output pin will be at Hi-Z and the DQ<sub>7</sub> bit will be at logic "1", and DQ<sub>6</sub> will stop toggling. The user must use the address of the erasing sector for reading DQ<sub>6</sub> and DQ<sub>7</sub> to determine if the erase operation has been suspended. Further writes of the Erase Suspend command are ignored.

When the erase operation has been suspended, the devices default to the erase-suspend-read mode. Reading data in this mode is the same as reading from the standard read mode except that the data must be read from sectors that have not been erase-suspended. Successively reading from the erase-suspended sector while the device is in the erase-suspend-read mode will cause DQ<sub>2</sub> to toggle. (See the section on DQ<sub>2</sub>.)

After entering the erase-suspend-read mode, the user can program the device by writing the appropriate command sequence for Program. This program mode is known as the erase-suspend-program mode. Again, programming in this mode is the same as programming in the regular Program mode except that the data must be programmed to sectors that are not erase-suspended. Successively reading from the erase-suspended sector while the devices are in the erase-suspend-program mode will cause DQ<sub>2</sub> to toggle. The end of the erase-suspended Program operation is detected by the RY/ $\overline{\text{BY}}$  output pin,  $\overline{\text{Data}}$  polling of DQ<sub>7</sub> or by the Toggle Bit I (DQ<sub>6</sub>) which is the same as the regular Program operation. Note that DQ<sub>7</sub> must be read from the Program address while DQ<sub>6</sub> can be read from any address within bank being erase-suspended.

To resume the operation of Sector Erase, the Resume command (30H) should be written to the bank being erase suspended. Any further writes of the Resume command at this point will be ignored. Another Erase Suspend command can be written after the chip has resumed erasing.

## Extended Command

### (1) Fast Mode

MBM29DL400TC/BC has Fast Mode function. This mode dispenses with the initial two unlock cycles required in the standard program command sequence by writing Fast Mode command into the command register. In this mode, the required bus cycle for programming is two cycles instead of four bus cycles in standard program command. (Do not write erase command in this mode.) The read operation is also executed after exiting this mode. To exit this mode, it is necessary to write Fast Mode Reset command into the command register. The first cycle must contain the bank address. (Refer to the Figure 28 Extended algorithm.) The  $V_{CC}$  active current is required even  $\overline{\text{CE}} = V_{IH}$  during Fast Mode.

### (2) Fast Programming

During Fast Mode, the programming can be executed with two bus cycles operation. The Embedded Program Algorithm is executed by writing program set-up command (A0H) and data write cycles (PA/PD). (Refer to the Figure 28 Extended algorithm.)

### (3) Extended Sector Protection

In addition to normal sector protection, the MBM29DL400TC/BC has Extended Sector Protection as extended function. This function enable to protect sector by forcing  $V_{ID}$  on  $\overline{\text{RESET}}$  pin and write a command sequence. Unlike conventional procedure, it is not necessary to force  $V_{ID}$  and control timing for control pins. The only  $\overline{\text{RESET}}$  pin requires  $V_{ID}$  for sector protection in this mode. The extended sector protect requires  $V_{ID}$  on  $\overline{\text{RESET}}$  pin. With this condition, the operation is initiated by writing the set-up command (60H) into the command register. Then, the sector addresses pins (A<sub>17</sub>, A<sub>16</sub>, A<sub>15</sub>, A<sub>14</sub>, A<sub>13</sub> and A<sub>12</sub>) and (A<sub>6</sub>, A<sub>1</sub>, A<sub>0</sub>) = (0, 1, 0) should be set to the sector to be protected (recommend to set  $V_{IL}$  for the other addresses pins), and write extended sector protect command (60H). A sector is typically protected in 150  $\mu$ s. To verify programming of the protection circuitry, the sector addresses pins (A<sub>17</sub>, A<sub>16</sub>, A<sub>15</sub>, A<sub>14</sub>, A<sub>13</sub> and A<sub>12</sub>) and (A<sub>6</sub>, A<sub>1</sub>, A<sub>0</sub>) = (0, 1, 0) should be set and write a command (40H). Following the command write, a logical "1" at device output DQ<sub>0</sub> will produce for protected sector in the read operation. If the output data is logical "0", please repeat to write extended sector protect command (60H) again. To terminate the operation, it is necessary to set  $\overline{\text{RESET}}$  pin to  $V_{IH}$ .

## Write Operation Status

Detailed in Table 9 are all the status flags that can determine the status of the bank for the current mode operation. The read operation from the bank where is not operate Embedded Algorithm returns a data of memory cell. These bits offer a method for determining whether a Embedded Algorithm is completed properly. The information on DQ<sub>2</sub> is address sensitive. This means that if an address from an erasing sector is consecutively read, then the DQ<sub>2</sub> bit will toggle. However, DQ<sub>2</sub> will not toggle if an address from a non-erasing sector is consecutively read. This allows the user to determine which sectors are erasing and which are not.

The status flag is not output from bank (non-busy bank) not executing Embedded Algorithm. For example, there is bank (busy bank) which is now executing Embedded Algorithm. When the read sequence is [1] <busy bank>, [2] <non-busy bank>, [3] <busy bank>, the DQ<sub>6</sub> is toggling in the case of [1] and [3]. In case of [2], the data of memory cell is outputted. In the erase-suspend read mode with the same read sequence, DQ<sub>6</sub> will not be toggled in the [1] and [3].

In the erase suspend read mode, DQ<sub>2</sub> is toggled in the [1] and [3]. In case of [2], the data of memory cell is outputted.

**Table 9 Hardware Sequence Flags**

Status			DQ <sub>7</sub>	DQ <sub>6</sub>	DQ <sub>5</sub>	DQ <sub>3</sub>	DQ <sub>2</sub>
In Progress	Embedded Program Algorithm		$\overline{DQ}_7$	Toggle	0	0	1
	Embedded Erase Algorithm		0	Toggle	0	1	Toggle (Note 1)
	Erase Suspended Mode	Erase Suspend Read (Erase Suspended Sector)	1	1	0	0	Toggle
		Erase Suspend Read (Non-Erase Suspended Sector)	Data	Data	Data	Data	Data
	Erase Suspend Program (Non-Erase Suspended Sector)		$\overline{DQ}_7$	Toggle	0	0	1 (Note 1)
Exceeded Time Limits	Embedded Program Algorithm		$\overline{DQ}_7$	Toggle	1	0	1
	Embedded Erase Algorithm		0	Toggle	1	1	N/A
	Erase Suspended Mode	Erase Suspend Program (Non-Erase Suspended Sector)	$\overline{DQ}_7$	Toggle	1	0	N/A

- Notes:**
1. Successive reads from the erasing or erase-suspend sector will cause DQ<sub>2</sub> to toggle. Reading from non-erase suspend sector address will indicate logic "1" at the DQ<sub>2</sub> bit.
  2. DQ<sub>0</sub> and DQ<sub>1</sub> are reserve pins for future use.
  3. DQ<sub>4</sub> is Fujitsu internal use only.

## DQ<sub>7</sub>

### Data Polling

The MBM29DL400TC/BC devices feature  $\overline{\text{Data}}$  Polling as a method to indicate to the host that the Embedded Algorithms are in progress or completed. During the Embedded Program Algorithm an attempt to read the devices will produce the complement of the data last written to DQ<sub>7</sub>. Upon completion of the Embedded Program Algorithm, an attempt to read the device will produce the true data last written to DQ<sub>7</sub>. During the Embedded Erase Algorithm, an attempt to read the device will produce a “0” at the DQ<sub>7</sub> output. Upon completion of the Embedded Erase Algorithm an attempt to read the device will produce a “1” at the DQ<sub>7</sub> output. The flowchart for  $\overline{\text{Data}}$  Polling (DQ<sub>7</sub>) is shown in Figure 23.

For programming, the  $\overline{\text{Data}}$  Polling is valid after the rising edge of fourth write pulse in the four write pulse sequence.

For chip erase and sector erase, the  $\overline{\text{Data}}$  Polling is valid after the rising edge of the sixth write pulse in the six write pulse sequence.  $\overline{\text{Data}}$  Polling must be performed at sector address within any of the sectors being erased and not a protected sector. Otherwise, the status may not be valid.

If a program address falls within a protected sector,  $\overline{\text{Data}}$  Polling on DQ<sub>7</sub> is active for approximately 1  $\mu\text{s}$ , then that bank returns to the read mode. After an erase command sequence is written, if all sectors selected for erasing are protected,  $\overline{\text{Data}}$  Polling on DQ<sub>7</sub> is active for approximately 100  $\mu\text{s}$ , then the bank returns to read mode.

Once the Embedded Algorithm operation is close to being completed, the MBM29DL400TC/BC data pins (DQ<sub>7</sub>) may change asynchronously while the output enable ( $\overline{\text{OE}}$ ) is asserted low. This means that the devices are driving status information on DQ<sub>7</sub> at one instant of time and then that byte's valid data at the next instant of time. Depending on when the system samples the DQ<sub>7</sub> output, it may read the status or valid data. Even if the device has completed the Embedded Algorithm operation and DQ<sub>7</sub> has a valid data, the data outputs on DQ<sub>0</sub> to DQ<sub>6</sub> may be still invalid. The valid data on DQ<sub>0</sub> to DQ<sub>7</sub> will be read on the successive read attempts.

The  $\overline{\text{Data}}$  Polling feature is only active during the Embedded Programming Algorithm, Embedded Erase Algorithm or sector erase time-out. (See Table 9.)

See Figure 9 for the  $\overline{\text{Data}}$  Polling timing specifications and diagrams.

## DQ<sub>6</sub>

### Toggle Bit I

The MBM29DL400TC/BC also feature the “Toggle Bit I” as a method to indicate to the host system that the Embedded Algorithms are in progress or completed.

During an Embedded Program or Erase Algorithm cycle, successive attempts to read ( $\overline{\text{OE}}$  toggling) data from the devices will result in DQ<sub>6</sub> toggling between one and zero. Once the Embedded Program or Erase Algorithm cycle is completed, DQ<sub>6</sub> will stop toggling and valid data will be read on the next successive attempts. During programming, the Toggle Bit I is valid after the rising edge of the fourth write pulse in the four write pulse sequence. For chip erase and sector erase, the Toggle Bit I is valid after the rising edge of the sixth write pulse in the six write pulse sequence. The Toggle Bit I is active during the sector time out.

In programming, if the sector being written to is protected, the toggle bit will toggle for about 2  $\mu\text{s}$  and then stop toggling without the data having changed. In erase, the devices will erase all the selected sectors except for the ones that are protected. If all selected sectors are protected, the chip will toggle the toggle bit for about 100  $\mu\text{s}$  and then drop back into read mode, having changed none of the data.

Either  $\overline{\text{CE}}$  or  $\overline{\text{OE}}$  toggling will cause the DQ<sub>6</sub> to toggle. In addition, an Erase Suspend/Resume command will cause the DQ<sub>6</sub> to toggle.

The system can use DQ<sub>6</sub> to determine whether a sector is actively erasing or is erase-suspended. When a bank is actively erasing (that is, the Embedded Erase Algorithm is in progress), DQ<sub>6</sub> toggles. When a bank enters the Erase Suspend mode, DQ<sub>6</sub> stops toggling. Successive read cycles during the erase-suspend-program cause DQ<sub>6</sub> to toggle.

To operate toggle bit function properly,  $\overline{CE}$  or  $\overline{OE}$  must be high when bank address is changed.

See Figure 10 for the Toggle Bit I timing specifications and diagrams.

## DQ<sub>5</sub>

### Exceeded Timing Limits

DQ<sub>5</sub> will indicate if the program or erase time has exceeded the specified limits (internal pulse count). Under these conditions DQ<sub>5</sub> will produce a “1”. This is a failure condition which indicates that the program or erase cycle was not successfully completed.  $\overline{Data}$  Polling is the only operating function of the devices under this condition. The  $\overline{CE}$  circuit will partially power down the device under these conditions (to approximately 2 mA). The  $\overline{OE}$  and  $\overline{WE}$  pins will control the output disable functions as described in Tables 2 and 3.

The DQ<sub>5</sub> failure condition may also appear if a user tries to program a non blank location without erasing. In this case the devices lock out and never complete the Embedded Algorithm operation. Hence, the system never reads a valid data on DQ<sub>7</sub> bit and DQ<sub>6</sub> never stops toggling. Once the devices have exceeded timing limits, the DQ<sub>5</sub> bit will indicate a “1.” Please note that this is not a device failure condition since the devices were incorrectly used. If this occurs, reset the device with command sequence.

## DQ<sub>3</sub>

### Sector Erase Timer

After the completion of the initial sector erase command sequence the sector erase time-out will begin. DQ<sub>3</sub> will remain low until the time-out is complete.  $\overline{Data}$  Polling and Toggle Bit are valid after the initial sector erase command sequence.

If  $\overline{Data}$  Polling or the Toggle Bit I indicates the device has been written with a valid erase command, DQ<sub>3</sub> may be used to determine if the sector erase timer window is still open. If DQ<sub>3</sub> is high (“1”) the internally controlled erase cycle has begun; attempts to write subsequent commands to the device will be ignored until the erase operation is completed as indicated by  $\overline{Data}$  Polling or Toggle Bit I. If DQ<sub>3</sub> is low (“0”), the device will accept additional sector erase commands. To insure the command has been accepted, the system software should check the status of DQ<sub>3</sub> prior to and following each subsequent Sector Erase command. If DQ<sub>3</sub> were high on the second status check, the command may not have been accepted.

See Table 9: Hardware Sequence Flags.

## DQ<sub>2</sub>

### Toggle Bit II

This toggle bit II, along with DQ<sub>6</sub>, can be used to determine whether the devices are in the Embedded Erase Algorithm or in Erase Suspend.

Successive reads from the erasing sector will cause DQ<sub>2</sub> to toggle during the Embedded Erase Algorithm. If the devices are in the erase-suspended-read mode, successive reads from the erase-suspended sector will cause DQ<sub>2</sub> to toggle. When the devices are in the erase-suspended-program mode, successive reads from the byte address of the non-erase suspended sector will indicate a logic “1” at the DQ<sub>2</sub> bit.

DQ<sub>6</sub> is different from DQ<sub>2</sub> in that DQ<sub>6</sub> toggles only when the standard program or Erase, or Erase Suspend Program operation is in progress. The behavior of these two status bits, along with that of DQ<sub>7</sub>, is summarized as follows:



# MBM29DL400TC-55/-70/-90/-12/MBM29DL400BC-55/-70/-90/-12

For example, DQ<sub>2</sub> and DQ<sub>6</sub> can be used together to determine if the erase-suspend-read mode is in progress. (DQ<sub>2</sub> toggles while DQ<sub>6</sub> does not.) See also Table 9 and Figure 19.

Furthermore, DQ<sub>2</sub> can also be used to determine which sector is being erased. When the device is in the erase mode, DQ<sub>2</sub> toggles if this bit is read from an erasing sector.

To operate toggle bit function properly,  $\overline{CE}$  or  $\overline{OE}$  must be high when bank address is changed.

Mode	DQ <sub>7</sub>	DQ <sub>6</sub>	DQ <sub>2</sub>
Program	$\overline{DQ_7}$	Toggle	1
Erase	0	Toggle	Toggle (Note)
Erase-Suspend Read (Erase-Suspended Sector) (Note 1)	1	1	Toggle
Erase-Suspend Program	$\overline{DQ_7}$	Toggle	1 (Note)

**Note:** Successive reads from the erasing or erase-suspend sector will cause DQ<sub>2</sub> to toggle. Reading from non-erase suspend sector address will indicate logic “1” at the DQ<sub>2</sub> bit.

## RY/ $\overline{BY}$

### Ready/Busy

The MBM29DL400TC/BC provide a RY/ $\overline{BY}$  open-drain output pin as a way to indicate to the host system that the Embedded Algorithms are either in progress or has been completed. If the output is low, the devices are busy with either a program or erase operation. If the output is high, the devices are ready to accept any read/write or erase operation. When the RY/ $\overline{BY}$  pin is low, the devices will not accept any additional program or erase commands. If the MBM29DL400TC/BC are placed in an Erase Suspend mode, the RY/ $\overline{BY}$  output will be high.

During programming, the RY/ $\overline{BY}$  pin is driven low after the rising edge of the fourth write pulse. During an erase operation, the RY/ $\overline{BY}$  pin is driven low after the rising edge of the sixth write pulse. The RY/ $\overline{BY}$  pin will indicate a busy condition during the  $\overline{RESET}$  pulse. Refer to Figure 11 and 12 for a detailed timing diagram. The RY/ $\overline{BY}$  pin is pulled high in standby mode.

Since this is an open-drain output, RY/ $\overline{BY}$  pins can be tied together in parallel with a pull-up resistor to V<sub>CC</sub>.

## Byte/Word Configuration

The  $\overline{BYTE}$  pin selects the byte (8-bit) mode or word (16-bit) mode for the MBM29DL400TC/BC devices. When this pin is driven high, the devices operate in the word (16-bit) mode. The data is read and programmed at DQ<sub>0</sub> to DQ<sub>15</sub>. When this pin is driven low, the devices operate in byte (8-bit) mode. Under this mode, the DQ<sub>15/A-1</sub> pin becomes the lowest address bit and DQ<sub>8</sub> to DQ<sub>14</sub> bits are tri-stated. However, the command bus cycle is always an 8-bit operation and hence commands are written at DQ<sub>0</sub> to DQ<sub>7</sub> and the DQ<sub>8</sub> to DQ<sub>15</sub> bits are ignored. Refer to Figures 13, 14 and 15 for the timing diagram.

## Data Protection

The MBM29DL400TC/BC are designed to offer protection against accidental erasure or programming caused by spurious system level signals that may exist during power transitions. During power up the devices automatically reset the internal state machine in the Read mode. Also, with its control register architecture, alteration of the memory contents only occurs after successful completion of specific multi-bus cycle command sequences.

The devices also incorporate several features to prevent inadvertent write cycles resulting from V<sub>CC</sub> power-up and power-down transitions or system noise.

## Low $V_{CC}$ Write Inhibit

To avoid initiation of a write cycle during  $V_{CC}$  power-up and power-down, a write cycle is locked out for  $V_{CC}$  less than 2.3 V (typically 2.4 V). If  $V_{CC} < V_{LKO}$ , the command register is disabled and all internal program/erase circuits are disabled. Under this condition the device will reset to the read mode. Subsequent writes will be ignored until the  $V_{CC}$  level is greater than  $V_{LKO}$ . It is the users responsibility to ensure that the control pins are logically correct to prevent unintentional writes when  $V_{CC}$  is above 2.3 V.

If Embedded Erase Algorithm is interrupted, there is possibility that the erasing sector(s) cannot be used.

## Write Pulse “Glitch” Protection

Noise pulses of less than 5 ns (typical) on  $\overline{OE}$ ,  $\overline{CE}$ , or  $\overline{WE}$  will not initiate a write cycle.

## Logical Inhibit

Writing is inhibited by holding any one of  $\overline{OE} = V_{IL}$ ,  $\overline{CE} = V_{IH}$ , or  $\overline{WE} = V_{IH}$ . To initiate a write cycle  $\overline{CE}$  and  $\overline{WE}$  must be a logical zero while  $\overline{OE}$  is a logical one.

## Power-Up Write Inhibit

Power-up of the devices with  $\overline{WE} = \overline{CE} = V_{IL}$  and  $\overline{OE} = V_{IH}$  will not accept commands on the rising edge of  $\overline{WE}$ . The internal state machine is automatically reset to the read mode on power-up.

# MBM29DL400TC-55/-70/-90/-12/MBM29DL400BC-55/-70/-90/-12

## ■ ABSOLUTE MAXIMUM RATINGS

Storage Temperature .....	-55°C to +125°C
Ambient Temperature with Power Applied .....	-40°C to +85°C
Voltage with respect to Ground All pins except A <sub>9</sub> , $\overline{OE}$ , $\overline{RESET}$ (Note 1) .....	-0.5 V to V <sub>CC</sub> +0.5 V
V <sub>CC</sub> (Note 1) .....	-0.5 V to +5.5 V
A <sub>9</sub> , $\overline{OE}$ , and $\overline{RESET}$ (Note 2) .....	-0.5 V to +13.0 V

- Notes:** 1. Minimum DC voltage on input or I/O pins are -0.5 V. During voltage transitions, inputs may negative overshoot V<sub>SS</sub> to -2.0 V for periods of up to 20 ns. Maximum DC voltage on output and I/O pins are V<sub>CC</sub> +0.5 V. During voltage transitions, outputs may positive overshoot to V<sub>CC</sub> +2.0 V for periods of up to 20 ns.
2. Minimum DC input voltage on A<sub>9</sub>,  $\overline{OE}$  and  $\overline{RESET}$  pins are -0.5 V. During voltage transitions, A<sub>9</sub>,  $\overline{OE}$  and  $\overline{RESET}$  pins may negative overshoot V<sub>SS</sub> to -2.0 V for periods of up to 20 ns. Maximum DC input voltage on A<sub>9</sub>,  $\overline{OE}$  and  $\overline{RESET}$  pins are +13.0 V which may positive overshoot to 14.0 V for periods of up to 20 ns. when V<sub>CC</sub> is applied.

**WARNING:** Semiconductor devices can be permanently damaged by application of stress (voltage, current, temperature, etc.) in excess of absolute maximum ratings. Do not exceed these ratings.

## ■ RECOMMENDED OPERATING RANGES

Ambient Temperature (T <sub>A</sub> )	
MBM29DL400TC/BC-55 .....	-20°C to +70°C
MBM29DL400TC/BC-70/-90/-12 .....	-40°C to +85°C
V <sub>CC</sub> Supply Voltages	
MBM29DL400TC/BC-55/-70 .....	+3.0 V to +3.6 V
MBM29DL400TC/BC-90/-12 .....	+2.7 V to +3.6 V

Operating ranges define those limits between which the functionality of the devices are guaranteed.

**WARNING:** The recommended operating conditions are required in order to ensure the normal operation of the semiconductor device. All of the device's electrical characteristics are warranted when the device is operated within these ranges.

Always use semiconductor devices within their recommended operating condition ranges. Operation outside these ranges may adversely affect reliability and could result in device failure.

No warranty is made with respect to uses, operating conditions, or combinations not represented on the data sheet. Users considering application outside the listed conditions are advised to contact their FUJITSU representatives beforehand.

## ■ MAXIMUM OVERSHOOT

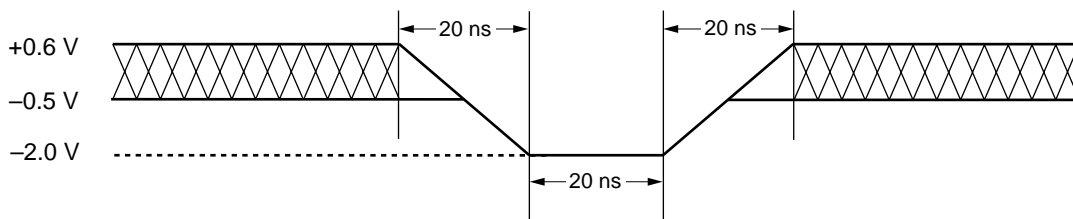

Figure 1 Maximum Negative Overshoot Waveform

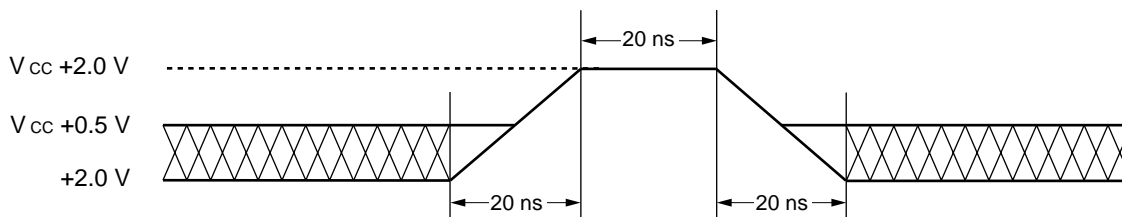
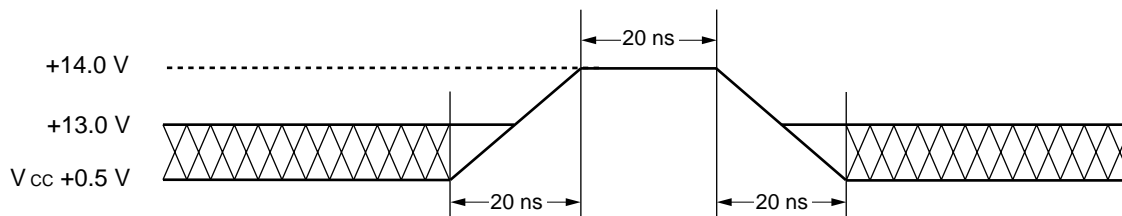

Figure 2 Maximum Positive Overshoot Waveform 1



\*: This waveform is applied for  $A_9$ ,  $\overline{OE}$ , and  $\overline{RESET}$ .

Figure 3 Maximum Positive Overshoot Waveform 2

## ■ DC CHARACTERISTICS

Parameter Symbol	Parameter Description	Test Conditions	Min.	Max.	Unit	
I <sub>LI</sub>	Input Leakage Current	V <sub>IN</sub> = V <sub>SS</sub> to V <sub>CC</sub> , V <sub>CC</sub> = V <sub>CC</sub> Max.	-1.0	+1.0	μA	
I <sub>LO</sub>	Output Leakage Current	V <sub>OUT</sub> = V <sub>SS</sub> to V <sub>CC</sub> , V <sub>CC</sub> = V <sub>CC</sub> Max.	-1.0	+1.0	μA	
I <sub>LIT</sub>	A <sub>9</sub> , $\overline{OE}$ , $\overline{RESET}$ Inputs Leakage Current	V <sub>CC</sub> = V <sub>CC</sub> Max. A <sub>9</sub> , $\overline{OE}$ , $\overline{RESET}$ = 12.5 V	—	35	μA	
I <sub>CC1</sub>	V <sub>CC</sub> Active Current (Note 1)	$\overline{CE} = V_{IL}$ , $\overline{OE} = V_{IH}$ , f=10 MHz	Byte	—	18	mA
			Word	—	20	
		$\overline{CE} = V_{IL}$ , $\overline{OE} = V_{IH}$ , f=5 MHz	Byte	—	8	mA
			Word	—	10	
I <sub>CC2</sub>	V <sub>CC</sub> Active Current (Note 2)	$\overline{CE} = V_{IL}$ , $\overline{OE} = V_{IH}$	—	35	mA	
I <sub>CC3</sub>	V <sub>CC</sub> Current (Standby)	V <sub>CC</sub> = V <sub>CC</sub> Max., $\overline{CE} = V_{CC} \pm 0.3$ V, $\overline{RESET} = V_{CC} \pm 0.3$ V	—	5	μA	
I <sub>CC4</sub>	V <sub>CC</sub> Current (Standby, Reset)	V <sub>CC</sub> = V <sub>CC</sub> Max., $\overline{RESET} = V_{SS} \pm 0.3$ V	—	5	μA	
I <sub>CC5</sub>	V <sub>CC</sub> Current (Automatic Sleep Mode) (Note 3)	V <sub>CC</sub> = V <sub>CC</sub> Max., $\overline{CE} = V_{SS} \pm 0.3$ V, $\overline{RESET} = V_{CC} \pm 0.3$ V V <sub>IN</sub> = V <sub>CC</sub> ± 0.3 V or V <sub>SS</sub> ± 0.3 V	—	5	μA	
I <sub>CC6</sub>	V <sub>CC</sub> Active Current (Note 5) (Read-While-Program)	$\overline{CE} = V_{IL}$ , $\overline{OE} = V_{IH}$	Byte	—	45	mA
			Word	—	45	
I <sub>CC7</sub>	V <sub>CC</sub> Active Current (Note 5) (Read-While-Erase)	$\overline{CE} = V_{IL}$ , $\overline{OE} = V_{IH}$	Byte	—	45	mA
			Word	—	45	
I <sub>CC8</sub>	V <sub>CC</sub> Active Current (Erase-Suspend-Program)	$\overline{CE} = V_{IL}$ , $\overline{OE} = V_{IH}$	—	35	mA	
V <sub>IL</sub>	Input Low Level	—	-0.5	0.6	V	
V <sub>IH</sub>	Input High Level	—	2.0	V <sub>CC</sub> +0.3	V	
V <sub>ID</sub>	Voltage for Autoselect and Sector Protection (A <sub>9</sub> , $\overline{OE}$ , $\overline{RESET}$ ) (Note 4)	—	11.5	12.5	V	
V <sub>OL</sub>	Output Low Voltage Level	I <sub>OL</sub> = 4.0 mA, V <sub>CC</sub> = V <sub>CC</sub> Min.	—	0.45	V	
V <sub>OH1</sub>	Output High Voltage Level	I <sub>OH</sub> = -2.0 mA, V <sub>CC</sub> = V <sub>CC</sub> Min.	2.4	—	V	
V <sub>OH2</sub>		I <sub>OH</sub> = -100 μA	V <sub>CC</sub> -0.4	—	V	
V <sub>LKO</sub>	Low V <sub>CC</sub> Lock-Out Voltage	—	2.3	2.5	V	

- Notes:**
- The I<sub>CC</sub> current listed includes both the DC operating current and the frequency dependent component.
  - I<sub>CC</sub> active while Embedded Algorithm (program or erase) is in progress.
  - Automatic sleep mode enables the low power mode when address remain stable for 150 ns.
  - Applicable for only V<sub>CC</sub> applying.
  - Embedded Algorithm (program or erase) is in progress. (@5 MHz)

## ■ AC CHARACTERISTICS

### • Read Only Operations Characteristics

Parameter Symbols		Description	Test Setup		-55 (Note)	-70 (Note)	-90 (Note)	-12 (Note)	Unit
JEDEC	Standard								
t <sub>AVAV</sub>	t <sub>RC</sub>	Read Cycle Time	—	Min.	55	70	90	120	ns
t <sub>AVQV</sub>	t <sub>ACC</sub>	Address to Output Delay	$\overline{CE} = V_{IL}$ $\overline{OE} = V_{IL}$	Max.	55	70	90	120	ns
t <sub>ELQV</sub>	t <sub>CE</sub>	Chip Enable to Output Delay	$\overline{OE} = V_{IL}$	Max.	55	70	90	120	ns
t <sub>GLQV</sub>	t <sub>OE</sub>	Output Enable to Output Delay	—	Max.	30	30	35	50	ns
t <sub>EHQZ</sub>	t <sub>DF</sub>	Chip Enable to Output High-Z	—	Max.	25	25	30	30	ns
t <sub>GHQZ</sub>	t <sub>DF</sub>	Output Enable to Output High-Z	—	Max.	25	25	30	30	ns
t <sub>AXQX</sub>	t <sub>OH</sub>	Output Hold Time From Addresses, $\overline{CE}$ or $\overline{OE}$ , Whichever Occurs First	—	Min.	0	0	0	0	ns
—	t <sub>READY</sub>	$\overline{RESET}$ Pin Low to Read Mode	—	Max.	20	20	20	20	μs
—	t <sub>ELFL</sub> t <sub>ELFH</sub>	$\overline{CE}$ or $\overline{BYTE}$ Switching Low or High	—	Max.	5	5	5	5	ns

**Note:** Test Conditions:

Output Load: 1 TTL gate and 30 pF (MBM29DL400TC/BC-55/-70)  
1 TTL gate and 100 pF (MBM29DL400TC/BC-90/-12)

Input rise and fall times: 5 ns

Input pulse levels: 0.0 V to 3.0 V

Timing measurement reference level

Input: 1.5 V

Output: 1.5 V

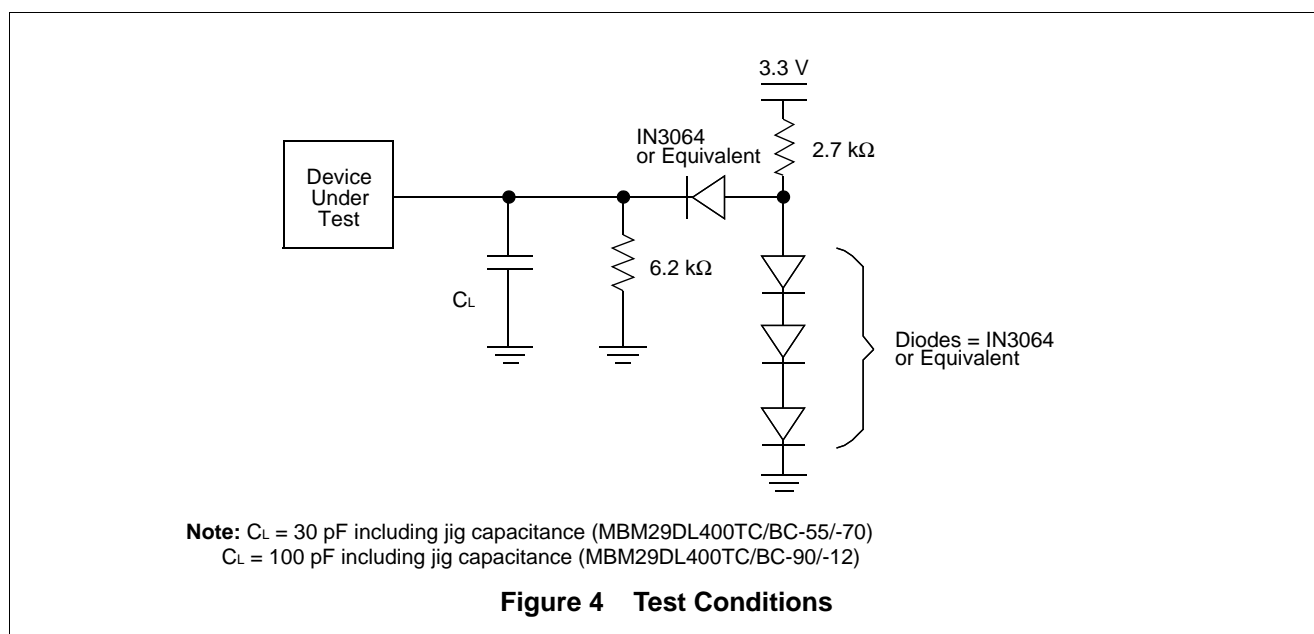

# MBM29DL400TC-55/-70/-90/-12/MBM29DL400BC-55/-70/-90/-12

• Write/Erase/Program Operations

Parameter Symbols		Description		MBM29DL400TC/BC				Unit
JEDEC	Standard			-55	-70	-90	-12	
t <sub>AVAV</sub>	t <sub>WC</sub>	Write Cycle Time	Min.	55	70	90	120	ns
t <sub>AVWL</sub>	t <sub>AS</sub>	Address Setup Time	Min.	0	0	0	0	ns
—	t <sub>ASO</sub>	Address Setup Time to $\overline{OE}$ Low During Toggle Bit Polling	Min.	15	15	15	15	ns
t <sub>WLAX</sub>	t <sub>AH</sub>	Address Hold Time	Min.	45	45	45	50	ns
—	t <sub>AHT</sub>	Address Hold Time from $\overline{CE}$ or $\overline{OE}$ High During Toggle Bit Polling	Min.	0	0	0	0	ns
t <sub>DVWH</sub>	t <sub>DS</sub>	Data Setup Time	Min.	30	35	45	50	ns
t <sub>WHDX</sub>	t <sub>DH</sub>	Data Hold Time	Min.	0	0	0	0	ns
—	t <sub>OEH</sub>	Output Enable Hold Time	Read	Min.	0	0	0	ns
			Toggle and $\overline{Data}$ Polling	Min.	10	10	10	10
—	t <sub>CEPH</sub>	$\overline{CE}$ High During Toggle Bit Polling	Min.	20	20	20	25	ns
—	t <sub>OEPH</sub>	$\overline{OE}$ High During Toggle Bit Polling	Min.	20	20	20	25	ns
t <sub>GHWL</sub>	t <sub>GHWL</sub>	Read Recover Time Before Write	Min.	0	0	0	0	ns
t <sub>GHEL</sub>	t <sub>GHEL</sub>	Read Recover Time Before Write	Min.	0	0	0	0	ns
t <sub>ELWL</sub>	t <sub>CS</sub>	$\overline{CE}$ Setup Time	Min.	0	0	0	0	ns
t <sub>WLEL</sub>	t <sub>WS</sub>	$\overline{WE}$ Setup Time	Min.	0	0	0	0	ns
t <sub>WHEH</sub>	t <sub>CH</sub>	$\overline{CE}$ Hold Time	Min.	0	0	0	0	ns
t <sub>EHWH</sub>	t <sub>WH</sub>	$\overline{WE}$ Hold Time	Min.	0	0	0	0	ns
t <sub>WLWH</sub>	t <sub>WP</sub>	Write Pulse Width	Min.	30	35	45	50	ns
t <sub>ELEH</sub>	t <sub>CP</sub>	$\overline{CE}$ Pulse Width	Min.	30	35	45	50	ns
t <sub>WHWL</sub>	t <sub>WPH</sub>	Write Pulse Width High	Min.	25	25	25	30	ns
t <sub>EHEL</sub>	t <sub>CPH</sub>	$\overline{CE}$ Pulse Width High	Min.	25	25	25	30	ns
t <sub>WHWH1</sub>	t <sub>WHWH1</sub>	Byte Programming Operation	Typ.	8	8	8	8	μs
t <sub>WHWH2</sub>	t <sub>WHWH2</sub>	Sector Erase Operation (Note 1)	Typ.	1	1	1	1	sec
—	t <sub>VCS</sub>	V <sub>CC</sub> Setup Time	Min.	50	50	50	50	μs
—	t <sub>VIDR</sub>	Rise Time to V <sub>ID</sub> (Note 2)	Min.	500	500	500	500	ns
—	t <sub>VLHT</sub>	Voltage Transition Time (Note 2)	Min.	4	4	4	4	μs
—	t <sub>WPP</sub>	Write Pulse Width (Note 2)	Min.	100	100	100	100	μs
—	t <sub>OESP</sub>	$\overline{OE}$ Setup Time to $\overline{WE}$ Active (Note 2)	Min.	4	4	4	4	μs

(Continued)

# MBM29DL400TC-55/-70/-90/-12/MBM29DL400BC-55/-70/-90/-12

(Continued)



Parameter Symbols		Description		MBM29DL400TC/BC				Unit
JEDEC	Standard			-55	-70	-90	-12	
—	t <sub>CSP</sub>	$\overline{CE}$ Setup Time to $\overline{WE}$ Active (Note 2)	Min.	4	4	4	4	μs
—	t <sub>RB</sub>	Recover Time From RY/ $\overline{BY}$	Min.	0	0	0	0	ns
—	t <sub>RP</sub>	$\overline{RESET}$ Pulse Width	Min.	500	500	500	500	ns
—	t <sub>RH</sub>	$\overline{RESET}$ Hold Time Before Read	Min.	200	200	200	200	ns
—	t <sub>FLQZ</sub>	$\overline{BYTE}$ Switching Low to Output High-Z	Max.	30	30	35	50	ns
—	t <sub>FHQV</sub>	$\overline{BYTE}$ Switching High to Output Active	Min.	30	30	35	50	ns
—	t <sub>BUSY</sub>	Program/Erase Valid to RY/ $\overline{BY}$ Delay	Max.	90	90	90	90	ns
—	t <sub>EOE</sub>	Delay Time from Embedded Output Enable	Max.	30	30	35	50	ns

- Notes:** 1. This does not include the preprogramming time.  
 2. This timing is for Sector Protection operation.



## SWITCHING WAVEFORMS

### Key to Switching Waveforms

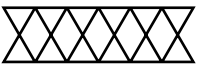
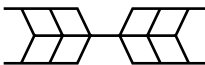
WAVEFORM	INPUTS	OUTPUTS
	Must Be Steady	Will Be Steady
	May Change from H to L	Will Be Changing from H to L
	May Change from L to H	Will Be Changing from L to H
	"H" or "L" Any Change Permitted	Changing State Unknown
	Does Not Apply	Center Line is High-Impedance "Off" State

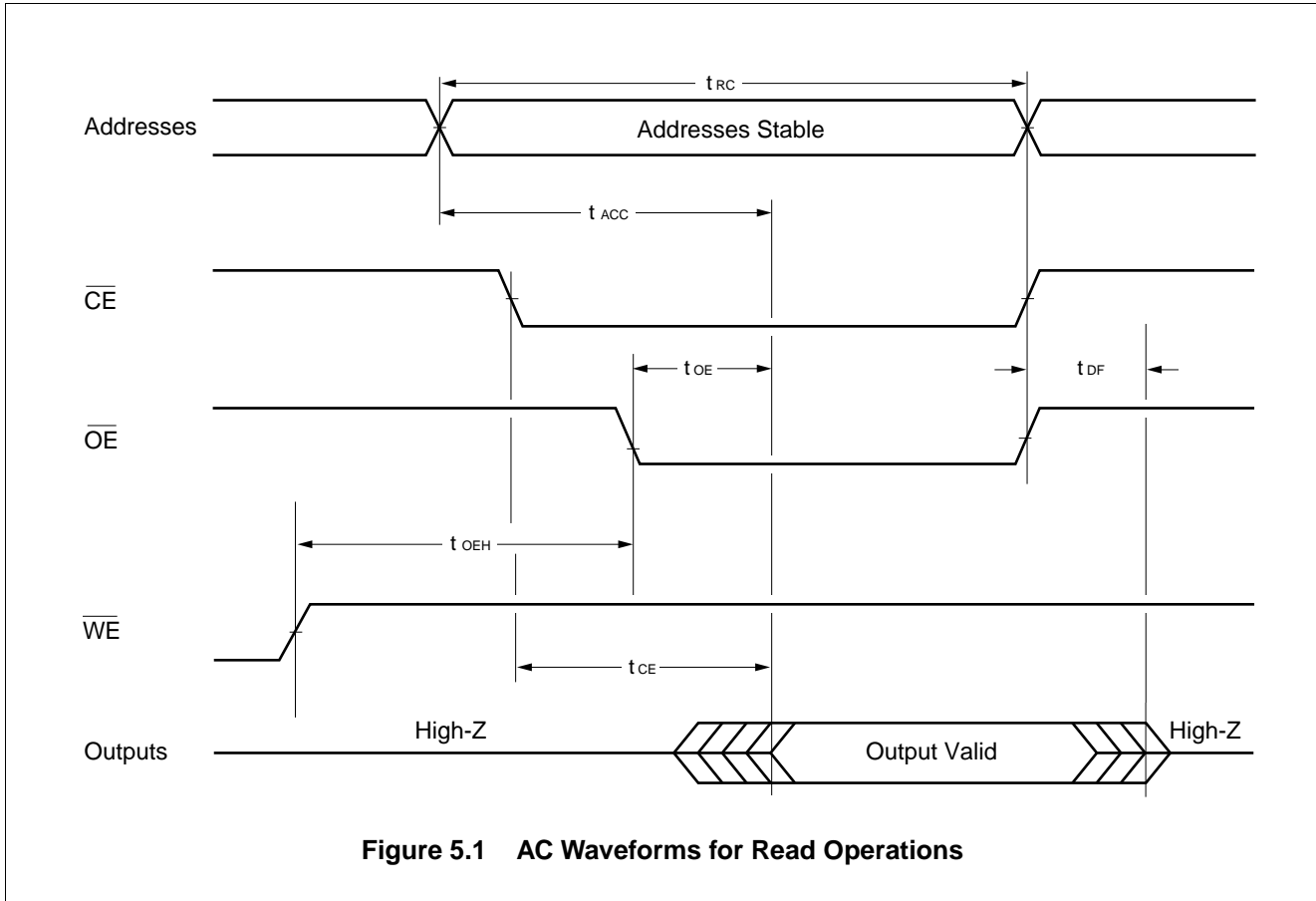
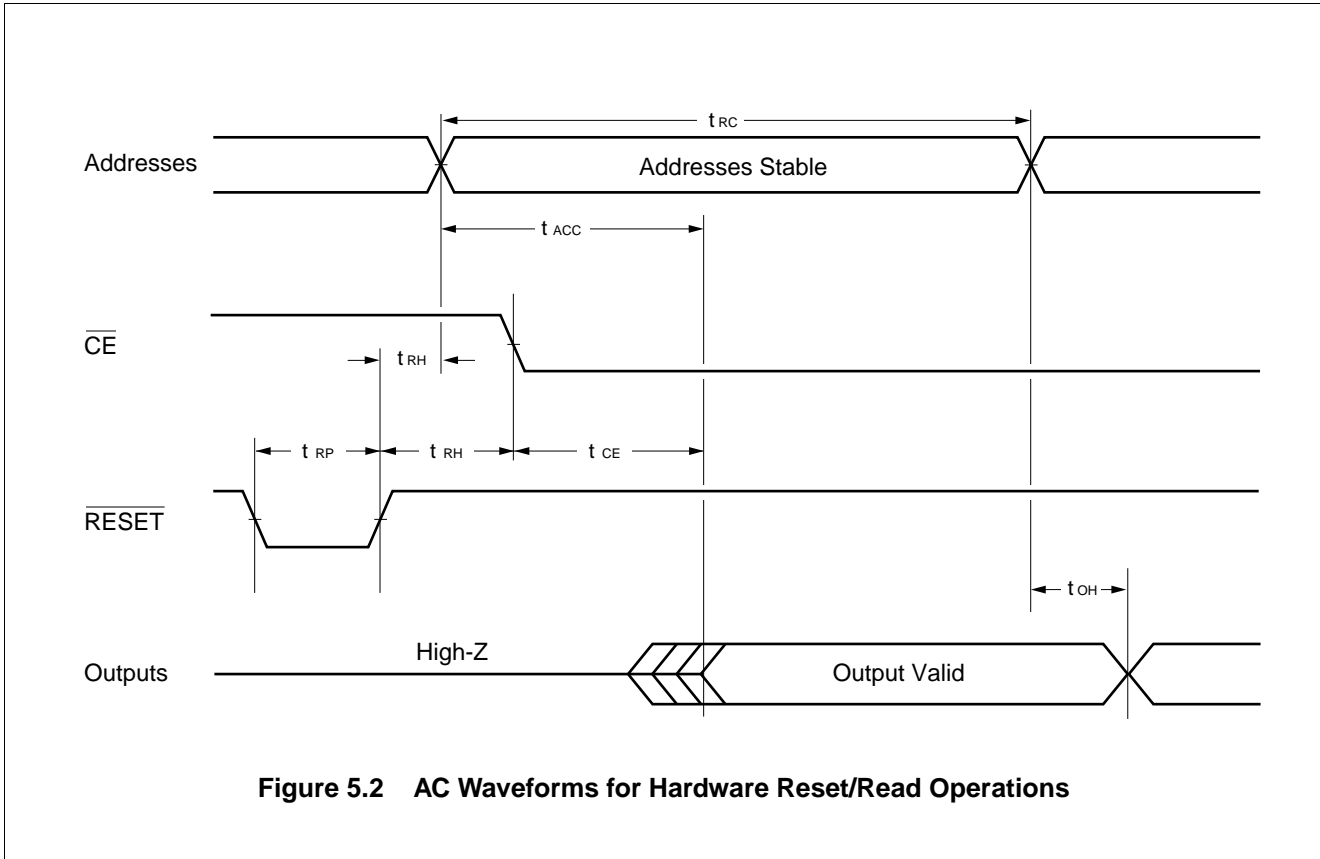
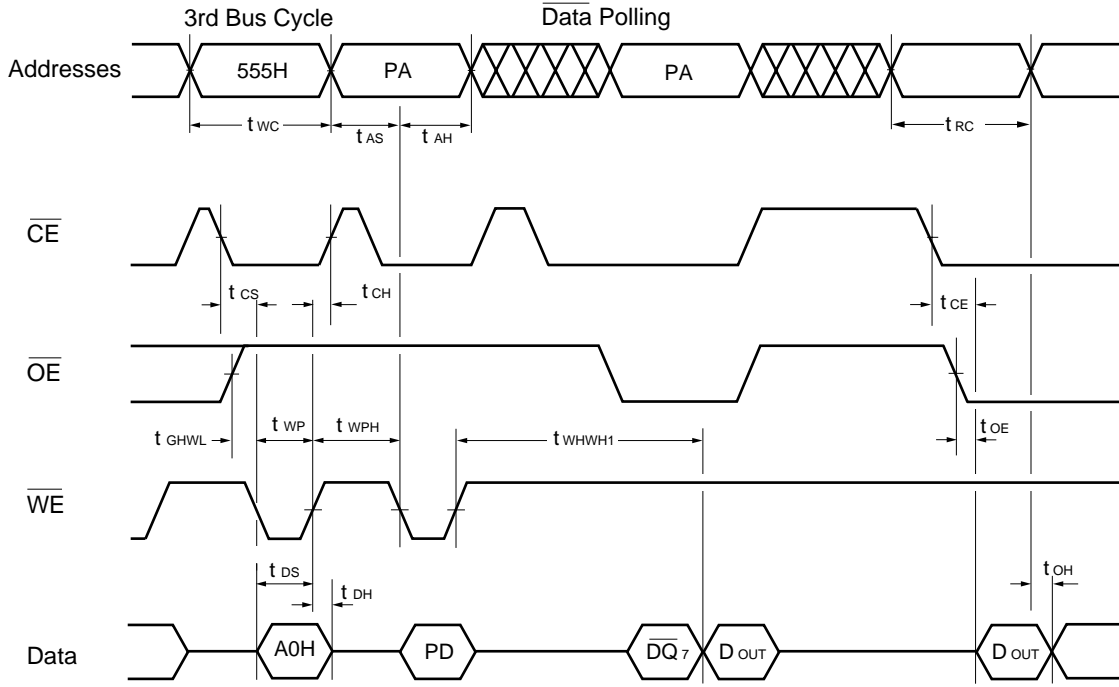

Figure 5.1 AC Waveforms for Read Operations

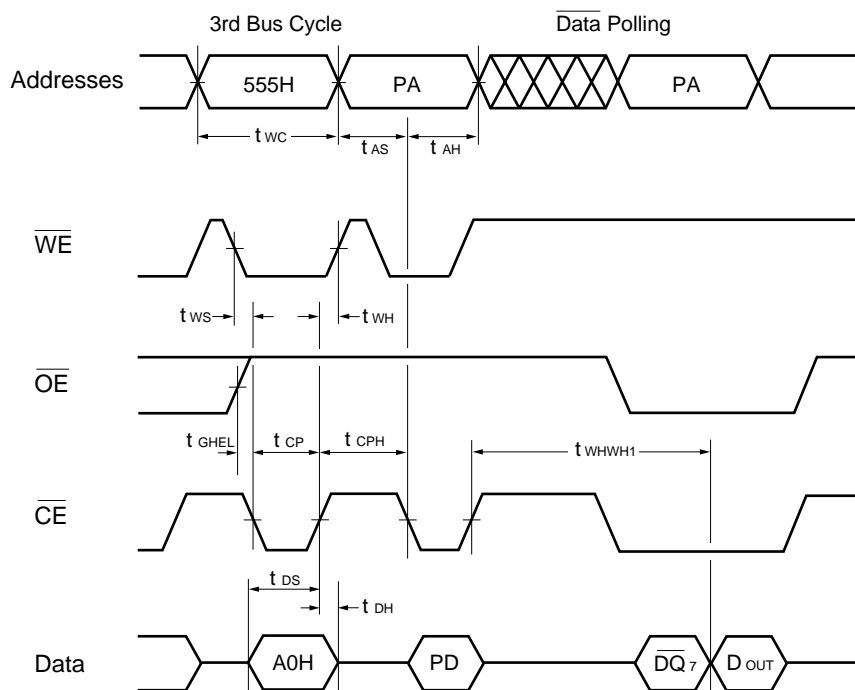

**Figure 5.2 AC Waveforms for Hardware Reset/Read Operations**



- Notes:**
1. PA is address of the memory location to be programmed.
  2. PD is data to be programmed at byte address.
  3.  $\overline{DQ}_7$  is the output of the complement of the data written to the device.
  4. D<sub>OUT</sub> is the output of the data written to the device.
  5. Figure indicates last two bus cycles out of four bus cycle sequence.
  6. These waveforms are for the ×16 mode. (The addresses differ from ×8 mode.)

Figure 6 Alternate  $\overline{WE}$  Controlled Program Operations



- Notes:**
1. PA is address of the memory location to be programmed.
  2. PD is data to be programmed at byte address.
  3.  $\overline{DQ}_7$  is the output of the complement of the data written to the device.
  4.  $D_{OUT}$  is the output of the data written to the device.
  5. Figure indicates last two bus cycles out of four bus cycle sequence.
  6. These waveforms are for the  $\times 16$  mode. (The addresses differ from  $\times 8$  mode.)

Figure 7 Alternate  $\overline{CE}$  Controlled Program Operations

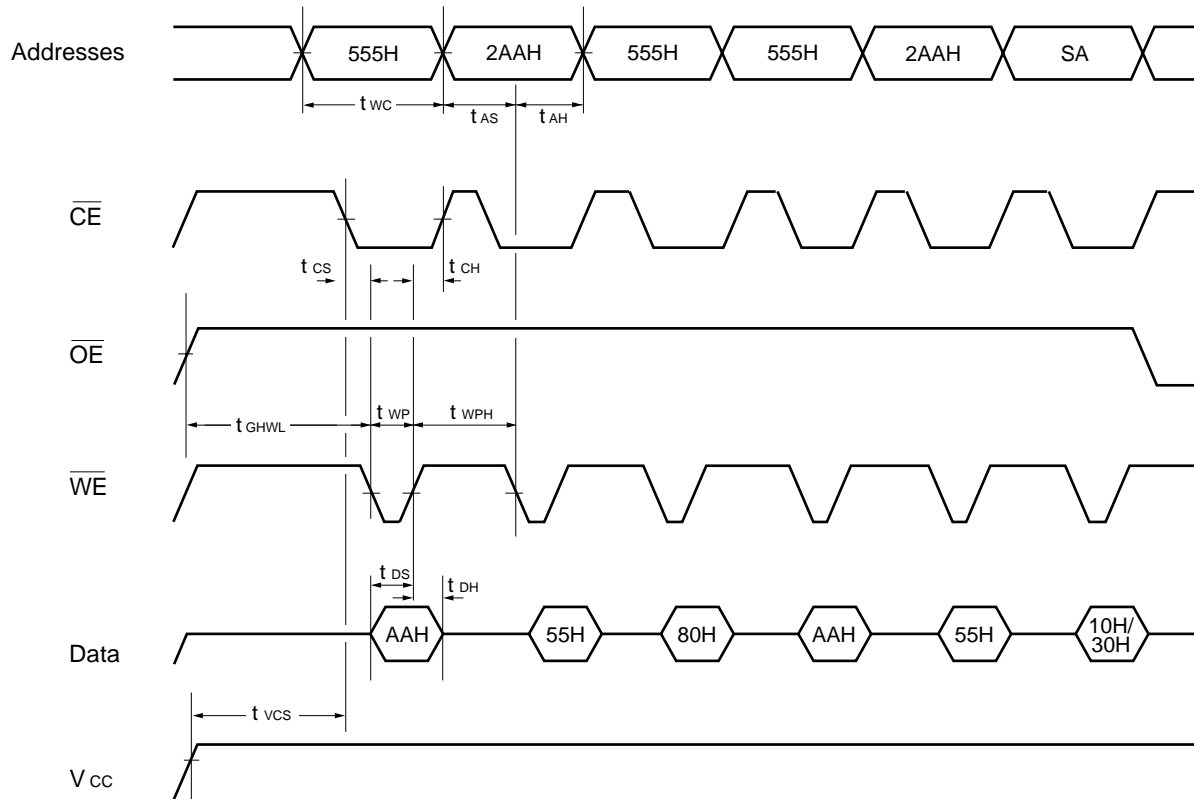

- Notes:**
1. SA is the sector address for Sector Erase. Addresses = 555H (Word), AAAH (Byte) for Chip Erase.
  2. These waveforms are for the  $\times 16$  mode. (The addresses differ from  $\times 8$  mode.)

Figure 8 AC Waveforms Chip/Sector Erase Operations

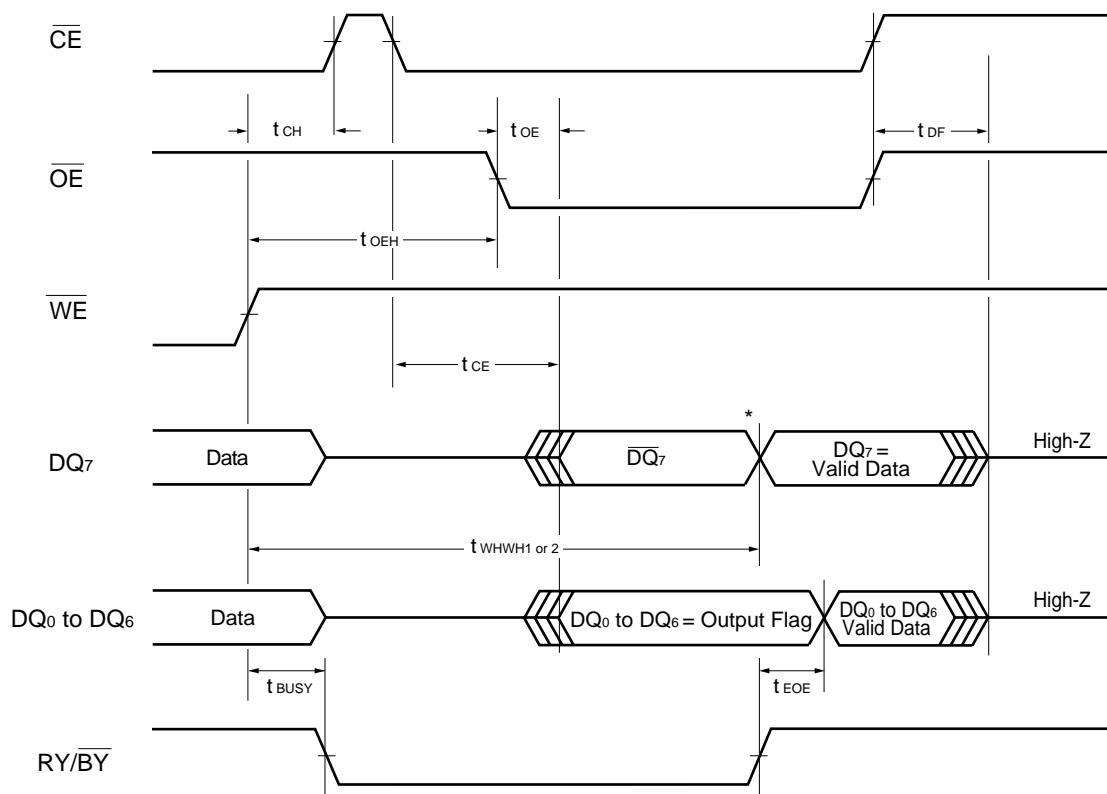

\* :  $DQ_7 = \text{Valid Data}$  (The device has completed the Embedded operation).

**Figure 9 AC Waveforms for  $\overline{Data}$  Polling during Embedded Algorithm Operations**

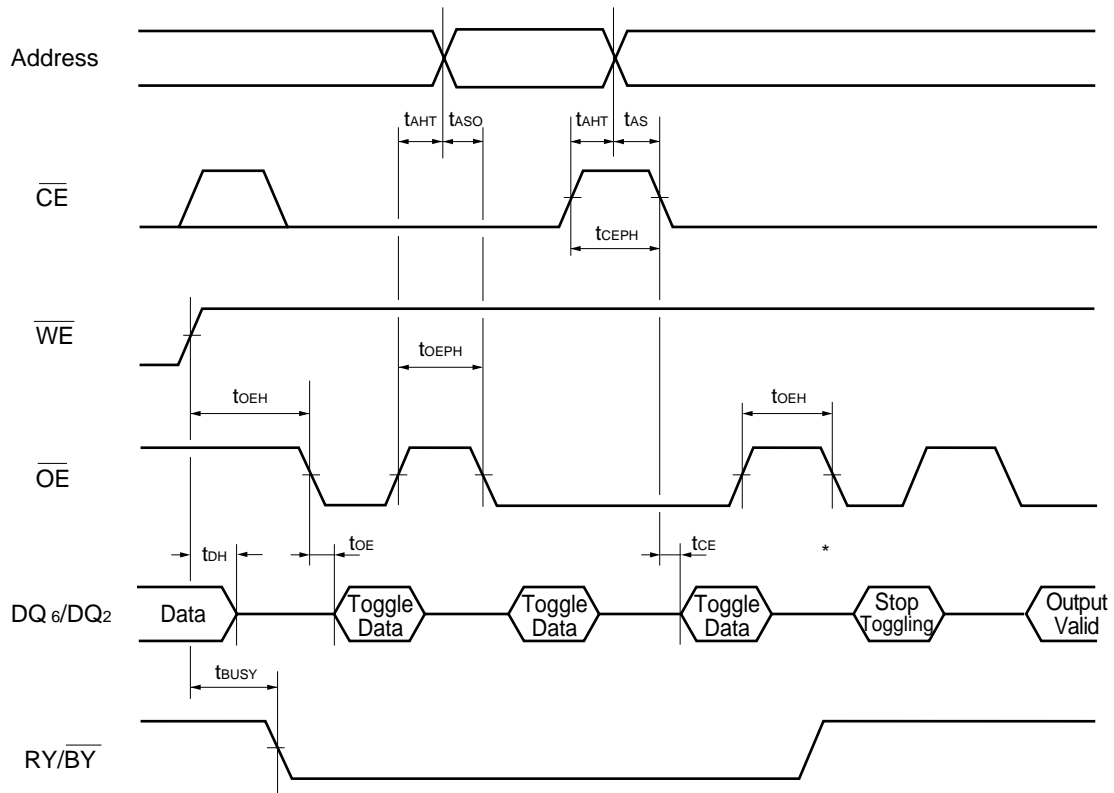

\* : DQ<sub>6</sub> stops toggling (The device has completed the Embedded operation).

**Figure 10 AC Waveforms for Toggle Bit I during Embedded Algorithm Operations**

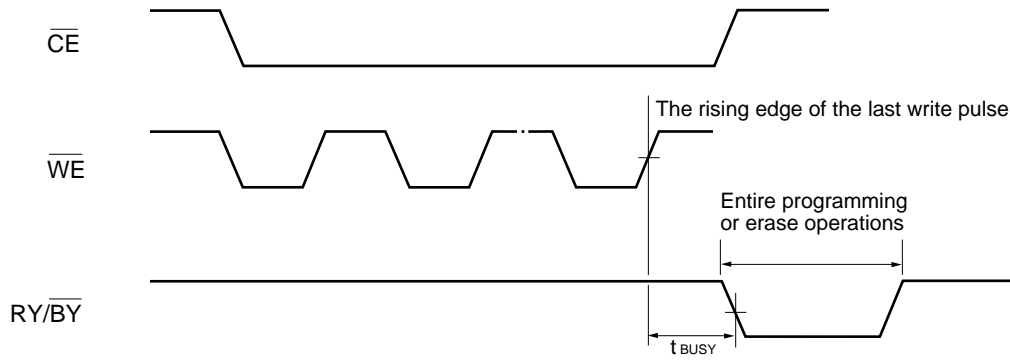

Figure 11  $\overline{RY/BY}$  Timing Diagram during Program/Erase Operations

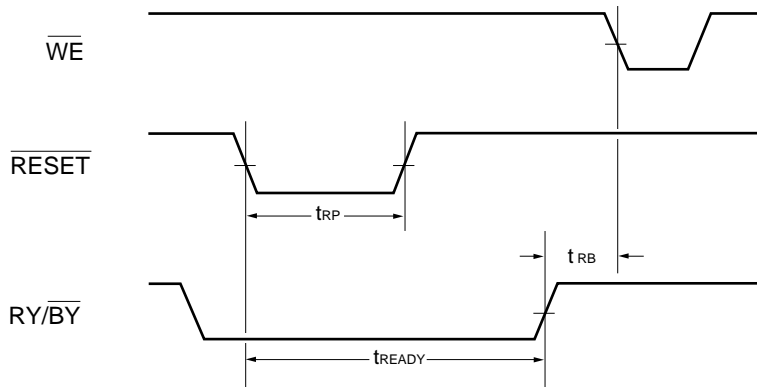
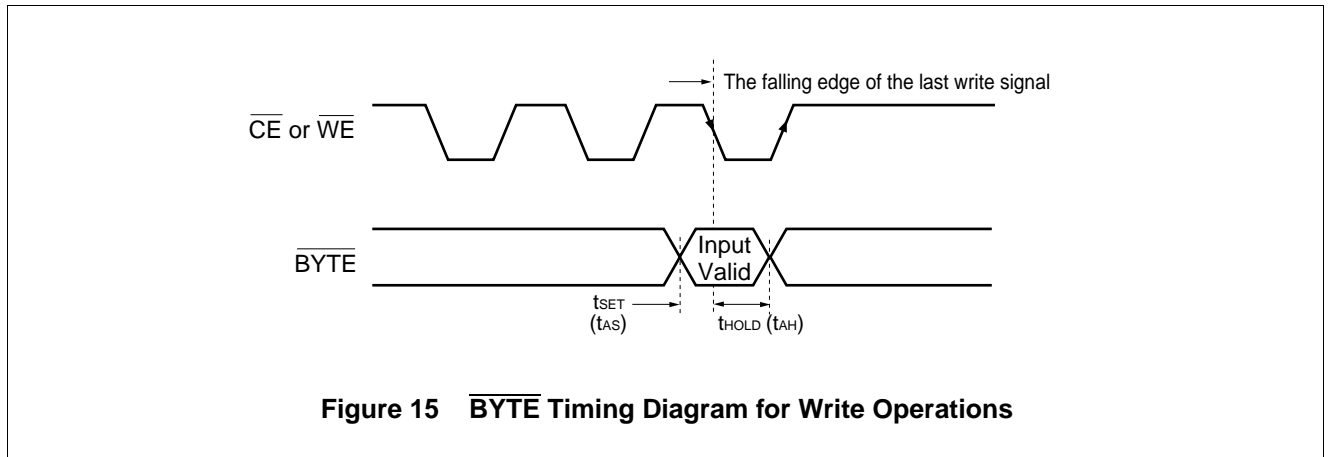
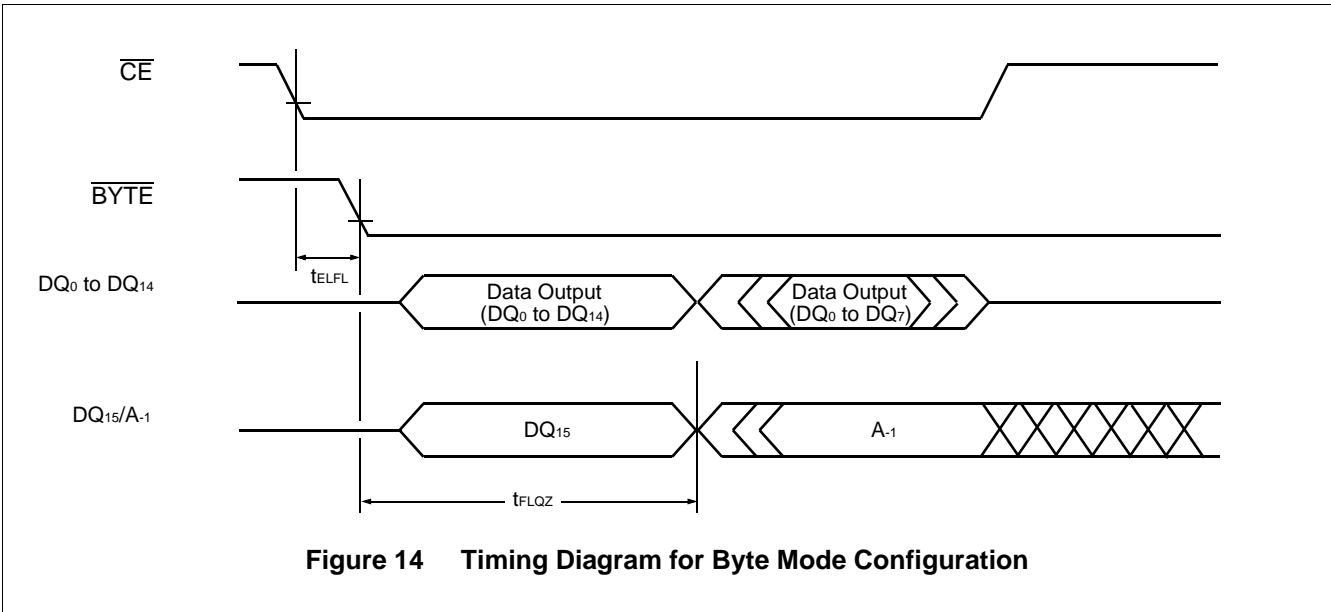
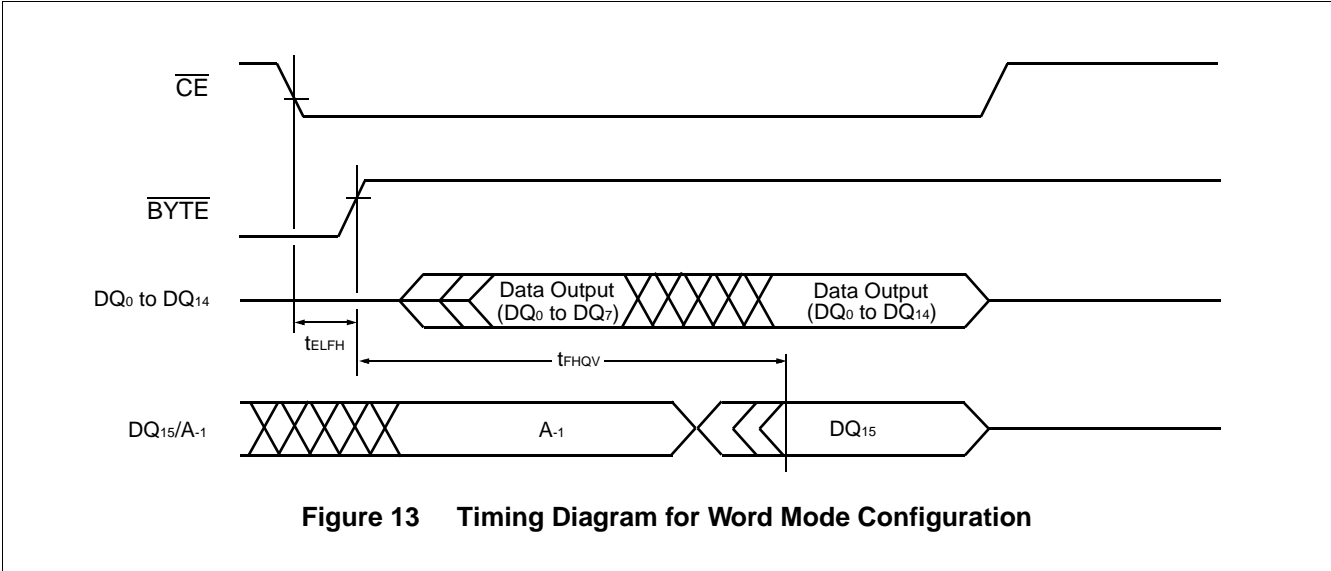
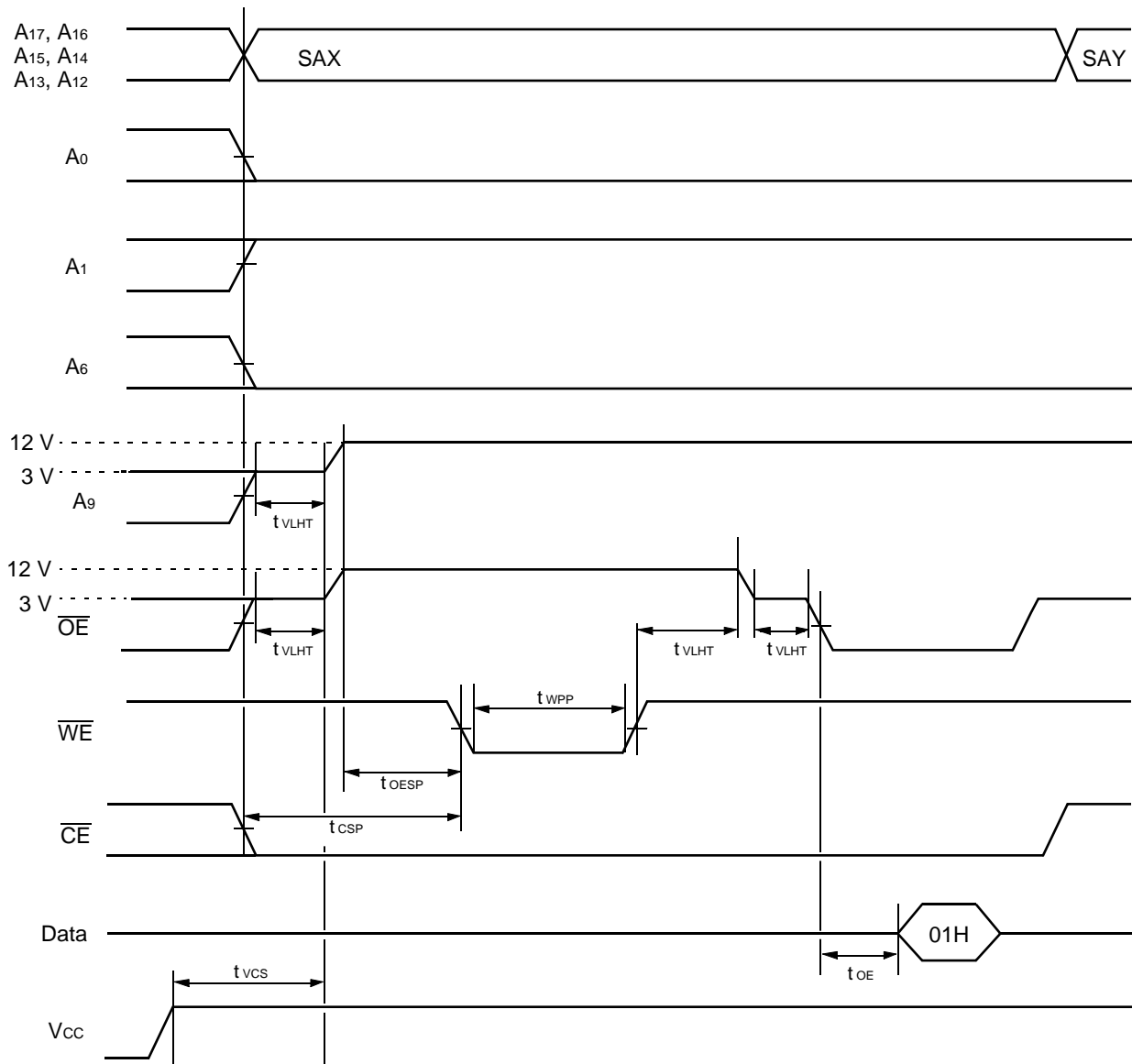

Figure 12  $\overline{RESET/RY/BY}$  Timing Diagram







SAX : Sector Address for initial sector  
 SAY : Sector Address for next sector  
**Note:** A-1 is  $V_{IL}$  on byte mode.

**Figure 16 AC Waveforms for Sector Protection**

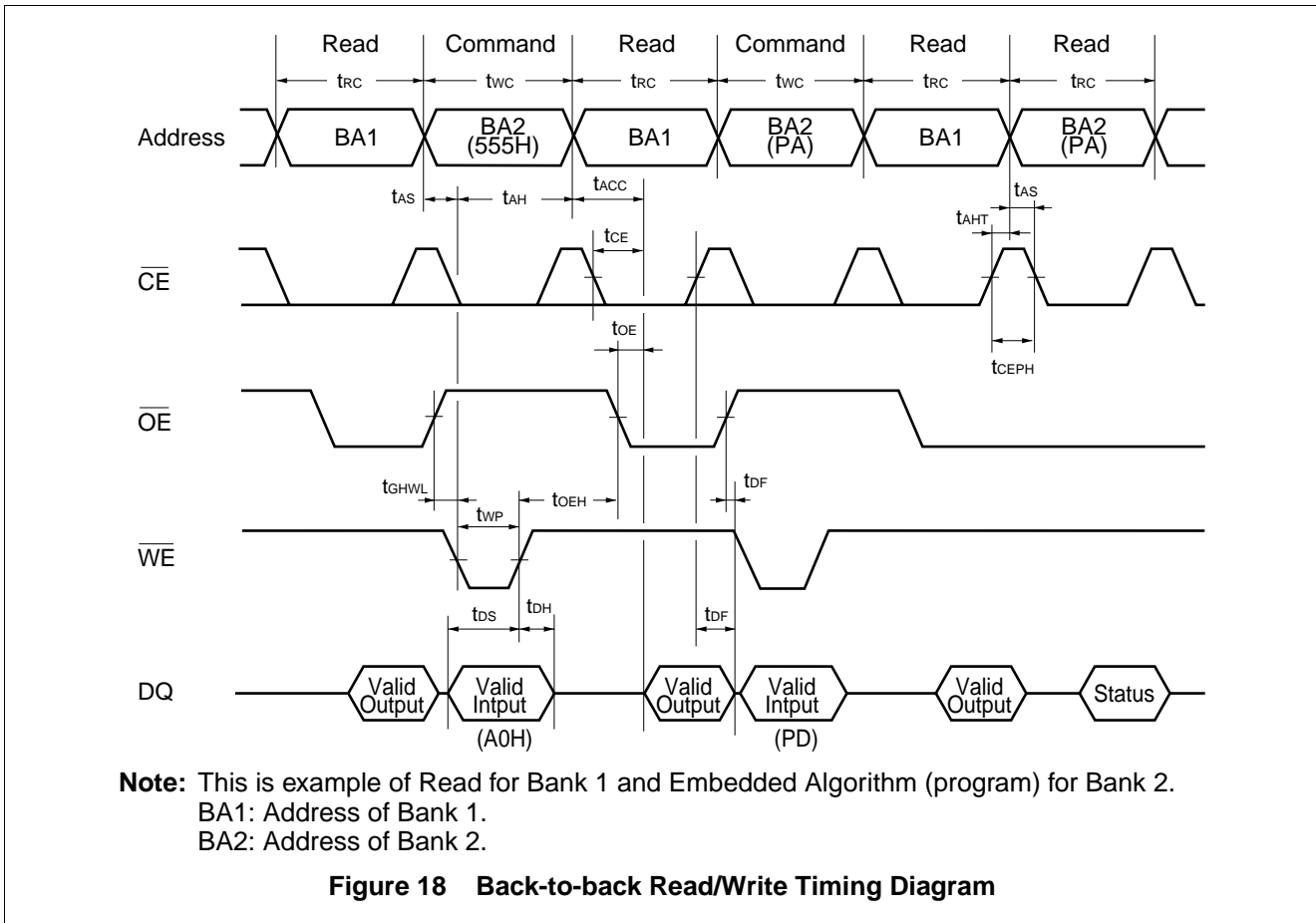
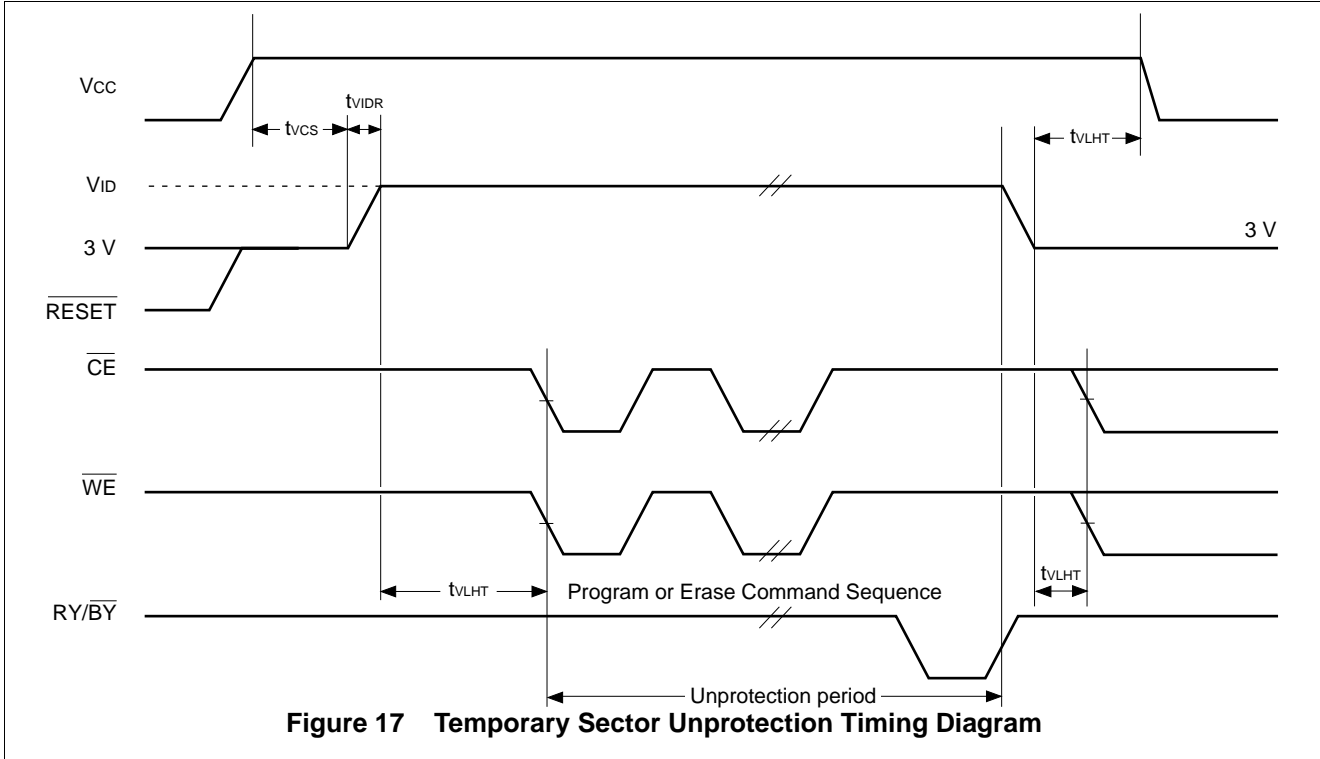

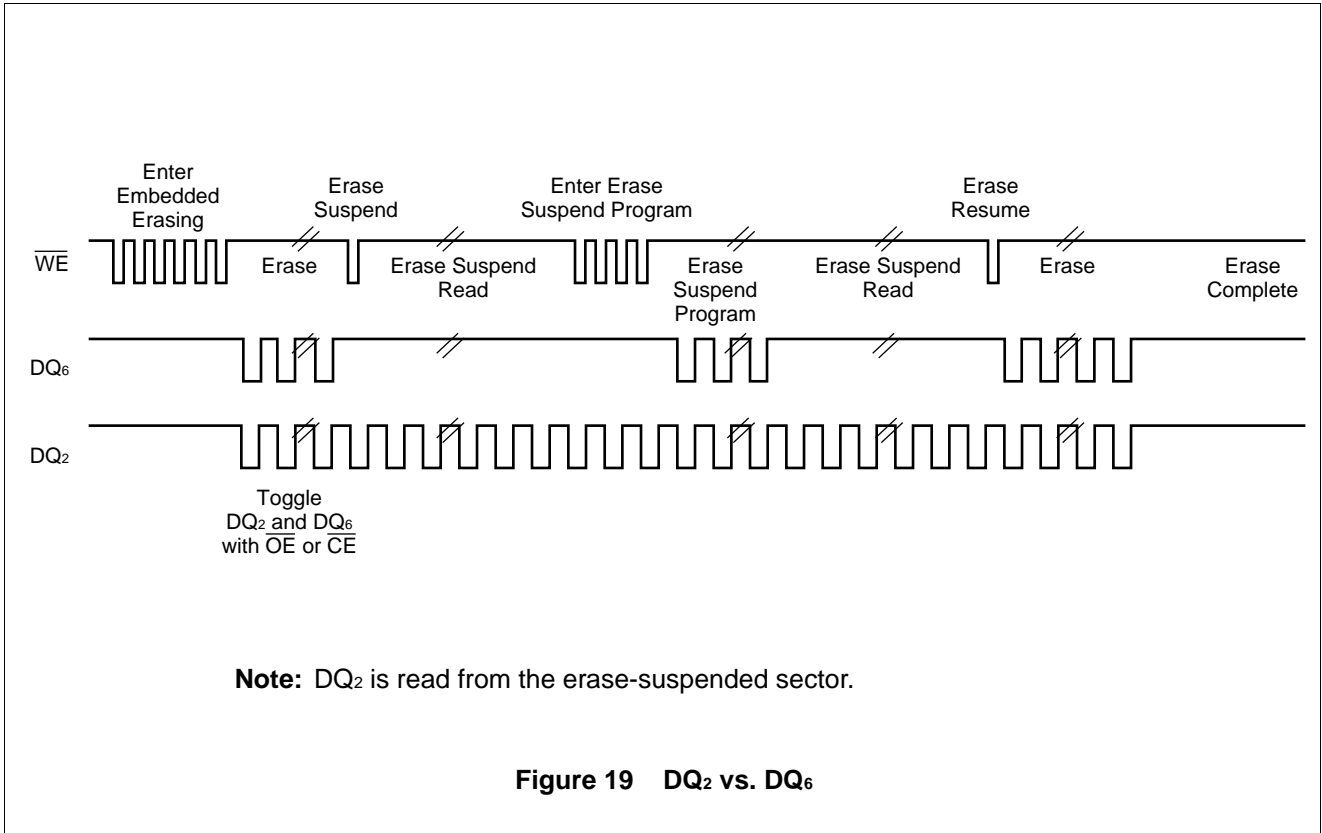

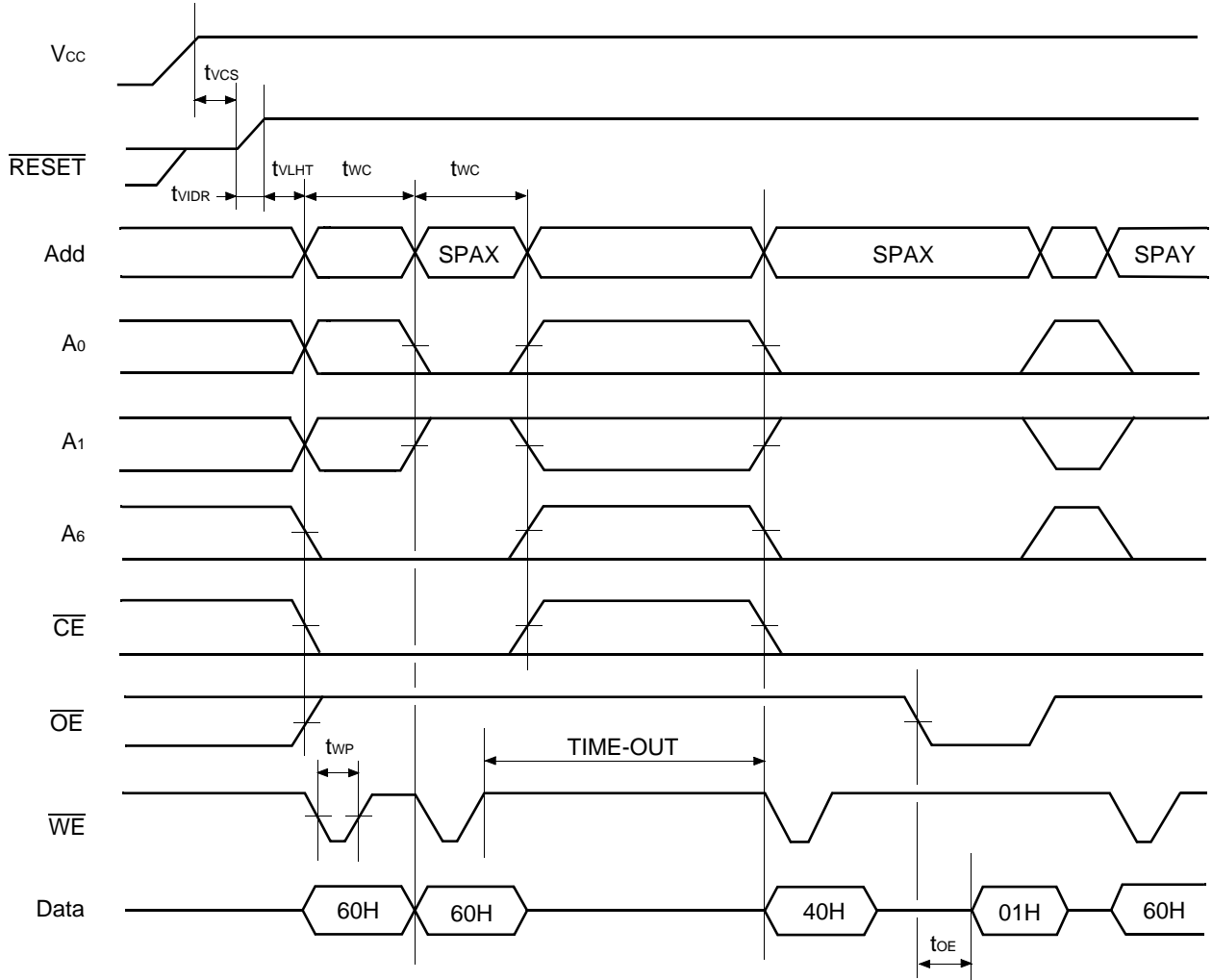

SPAX : Sector Address to be protected  
 SPAY : Next Sector Address to be protected  
 TIME-OUT : Time-Out window = 150  $\mu$ s (min)

Figure 20 Extended Sector Protection Timing Diagram

EMBEDDED ALGORITHMS

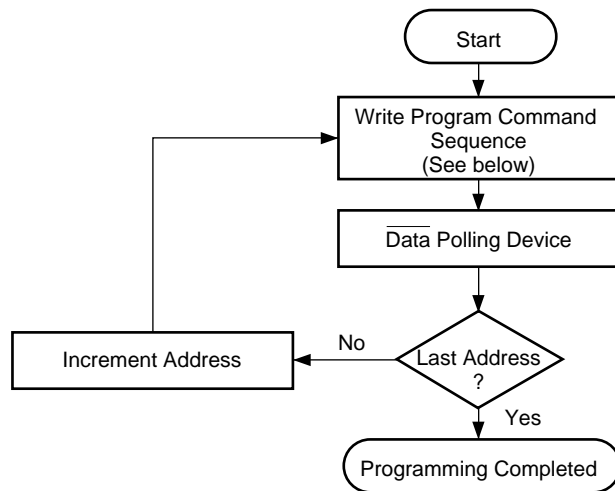

Program Command Sequence\* (Address/Command):

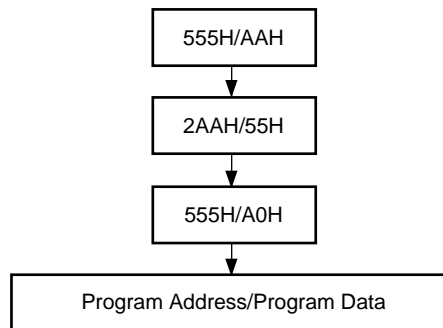

\* : The sequence is applied for × 16 mode.  
The addresses differ from × 8 mode.

Figure 21 Embedded Program™ Algorithm

EMBEDDED ALGORITHMS

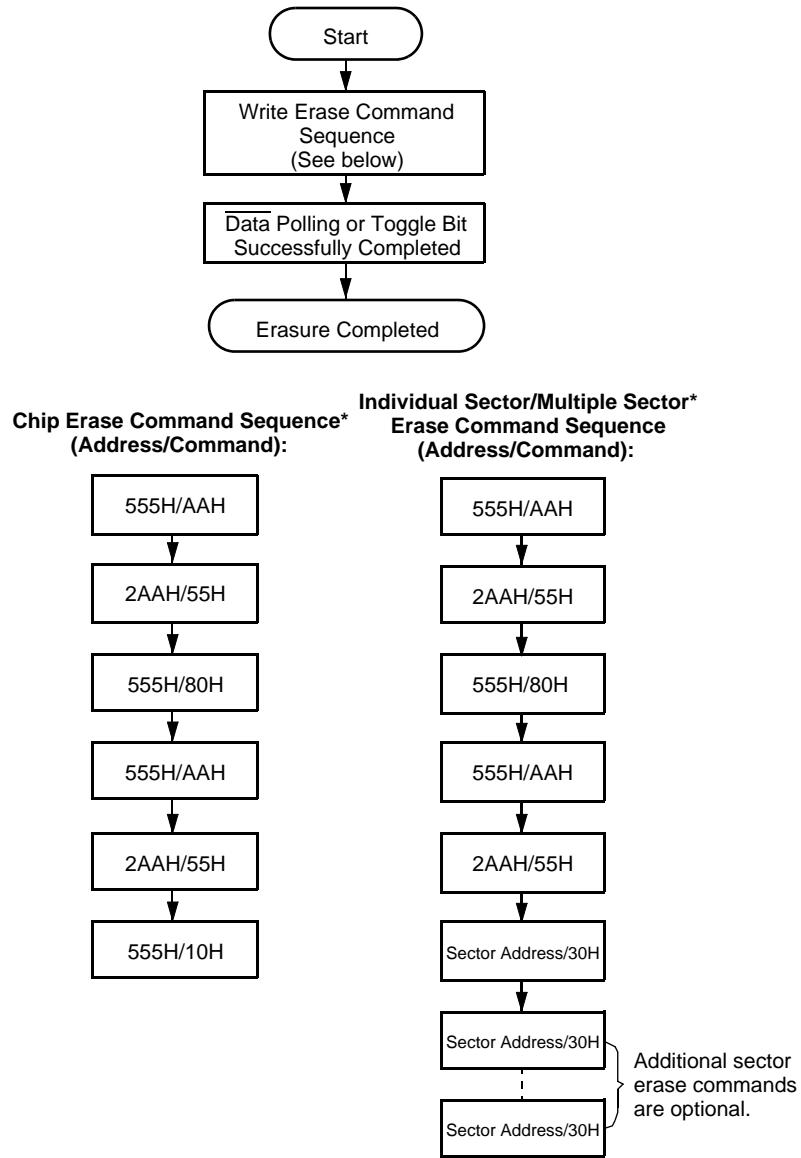

\* : The sequence is applied for × 16 mode.  
The addresses differ from × 8 mode.

Figure 22 Embedded Erase™ Algorithm

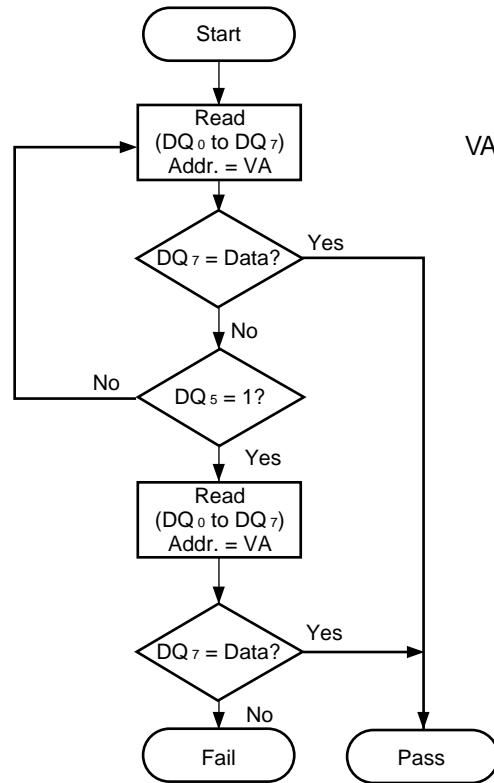

VA = Byte address for programming  
 = Any of the sector addresses within the sector being erased during sector erase or multiple sector erases operation  
 = Any of the sector addresses within the sector not being protected during chip erase

**Note:** DQ<sub>7</sub> is rechecked even if DQ<sub>5</sub> = "1" because DQ<sub>7</sub> may change simultaneously with DQ<sub>5</sub>.

Figure 23 Data Polling Algorithm



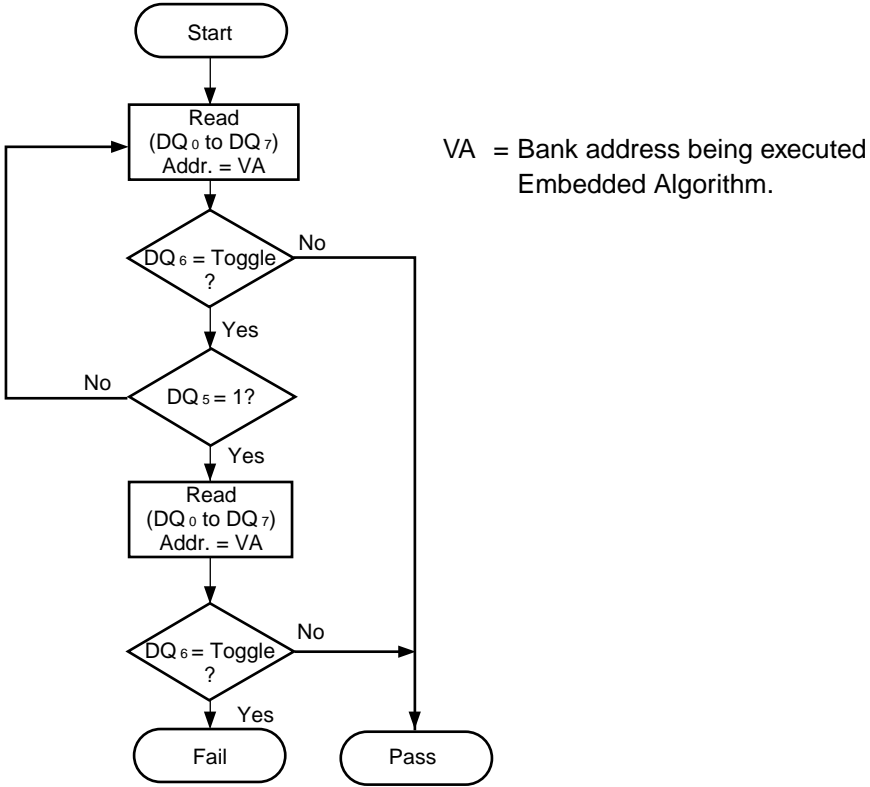

**Note:** DQ<sub>6</sub> is rechecked even if DQ<sub>5</sub> = "1" because DQ<sub>6</sub> may stop toggling at the same time as DQ<sub>5</sub> changing to "1" .

Figure 24 Toggle Bit Algorithm

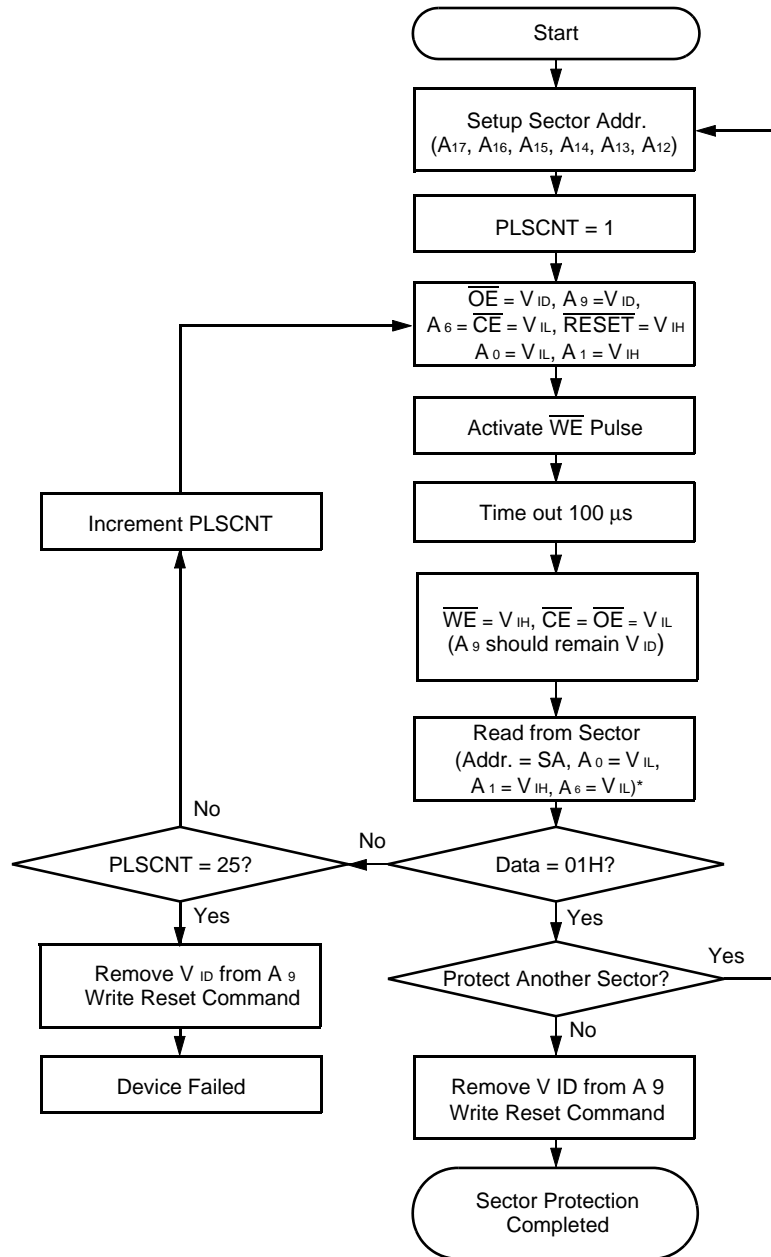

\* : A-1 is V<sub>IL</sub> on byte mode.

Figure 25 Sector Protection Algorithm

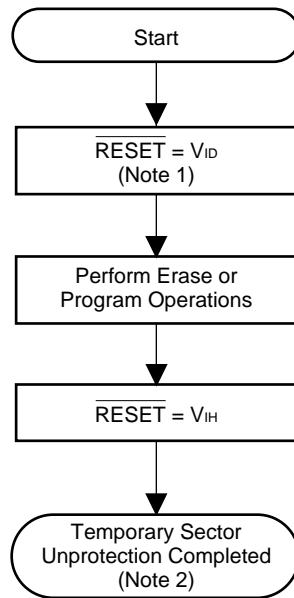

- Notes:** 1. All protected sectors are unprotected.  
2. All previously protected sectors are protected once again.

**Figure 26 Temporary Sector Unprotection Algorithm**

FAST MODE ALGORITHM

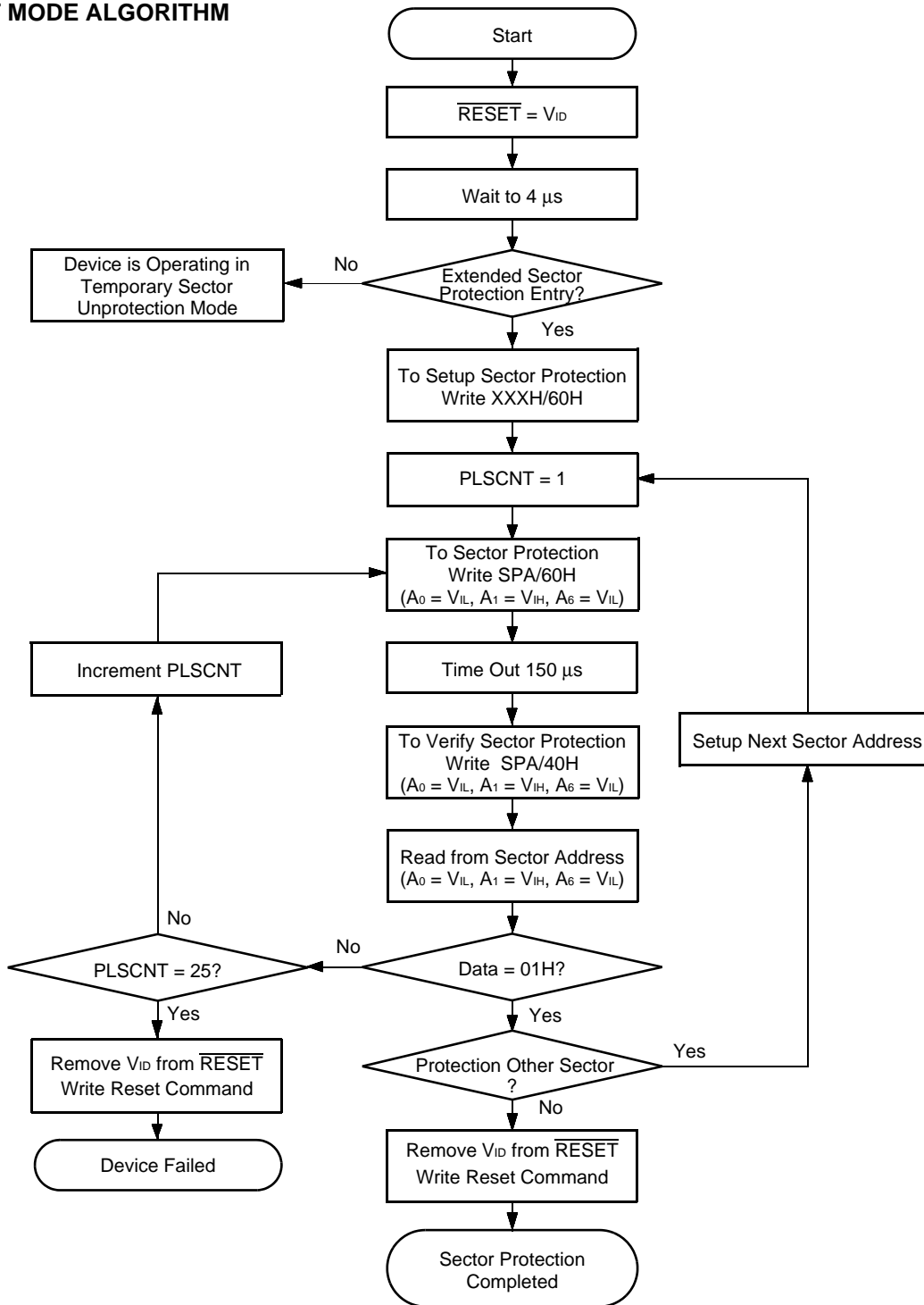
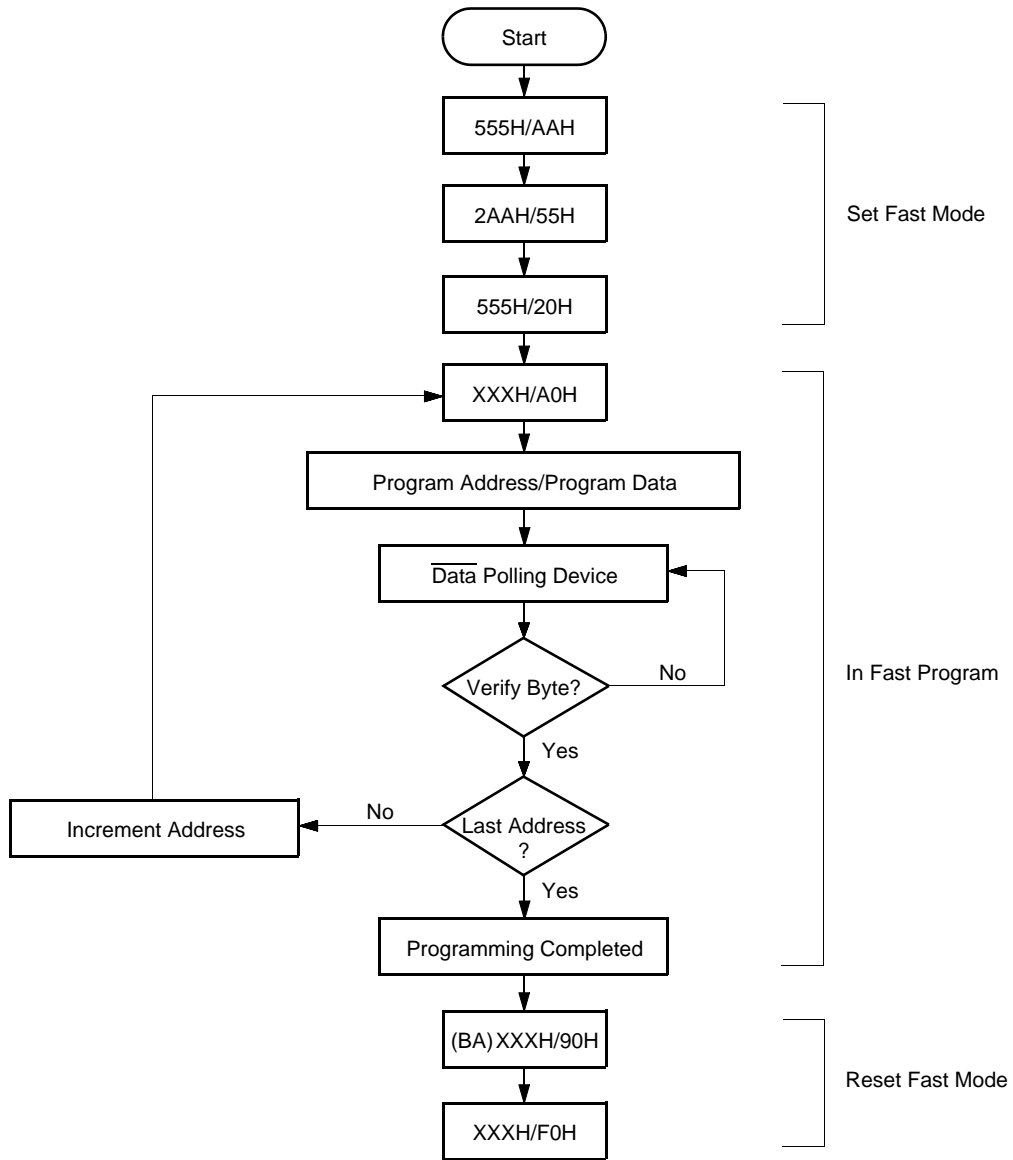

Figure 27 Extended Sector Protection Algorithm

FAST MODE ALGORITHM



\* : The sequence is applied for × 16 mode.  
The addresses differ from × 8 mode.

Figure 28 Embedded Program™ Algorithm for Fast Mode

## ■ ERASE AND PROGRAMMING PERFORMANCE

Parameter	Limits			Unit	Comments
	Min.	Typ.	Max.		
Sector Erase Time	—	1	10	sec	Excludes programming time prior to erasure
Word Programming Time	—	16	360	μs	Excludes system-level overhead
Byte Programming Time	—	8	300	μs	
Chip Programming Time	—	4.2	12.5	sec	Excludes system-level overhead
Program/Erase Cycle	100,000	—	—	cycles	—

## ■ TSOP(I) PIN CAPACITANCE

Parameter Symbol	Parameter Description	Test Setup	Typ.	Max.	Unit
C <sub>IN</sub>	Input Capacitance	V <sub>IN</sub> = 0	6	7.5	pF
C <sub>OUT</sub>	Output Capacitance	V <sub>OUT</sub> = 0	8.5	12	pF
C <sub>IN2</sub>	Control Pin Capacitance	V <sub>IN</sub> = 0	8	10	pF

**Note:** Test conditions T<sub>A</sub> = 25°C, f = 1.0 MHz

# MBM29DL400TC-55/-70/-90/-12/MBM29DL400BC-55/-70/-90/-12

## PACKAGE DIMENSIONS

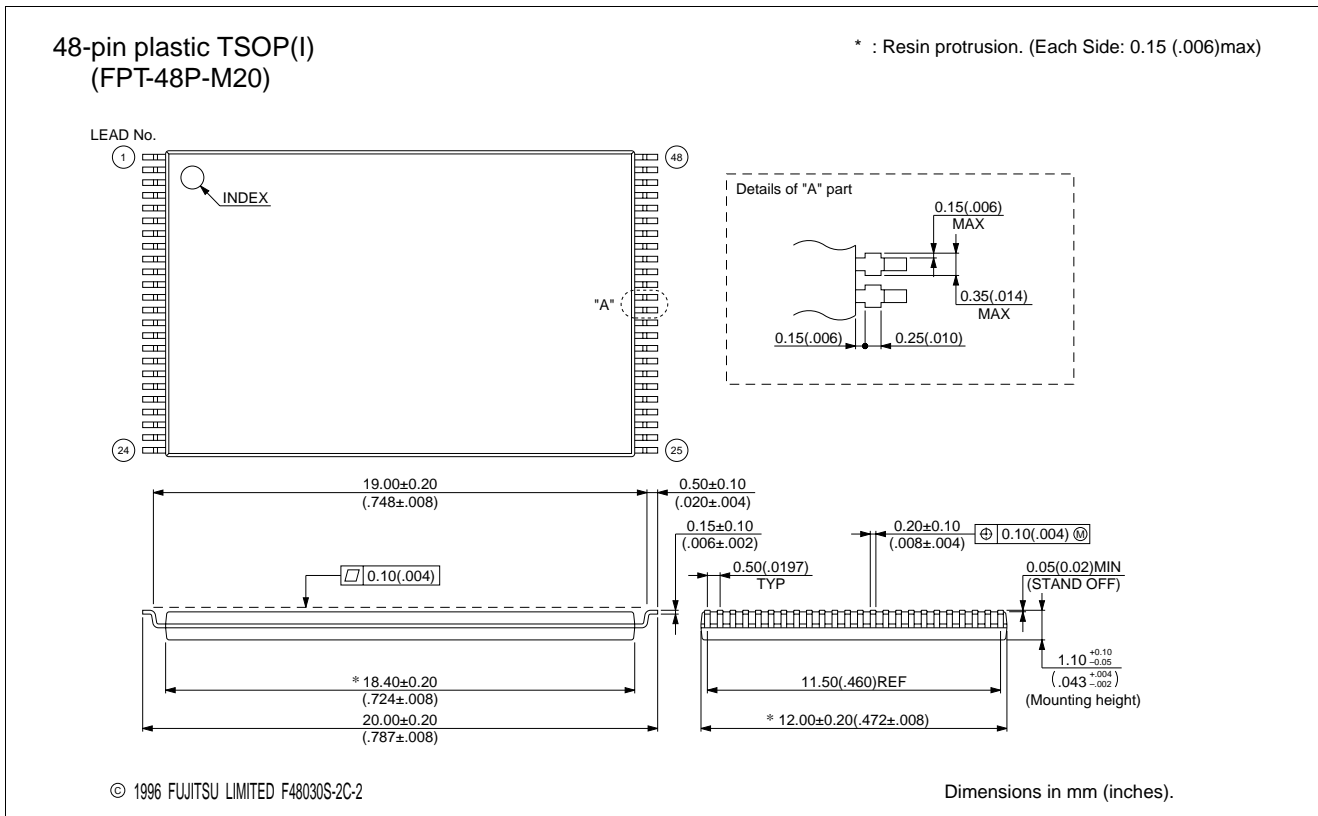
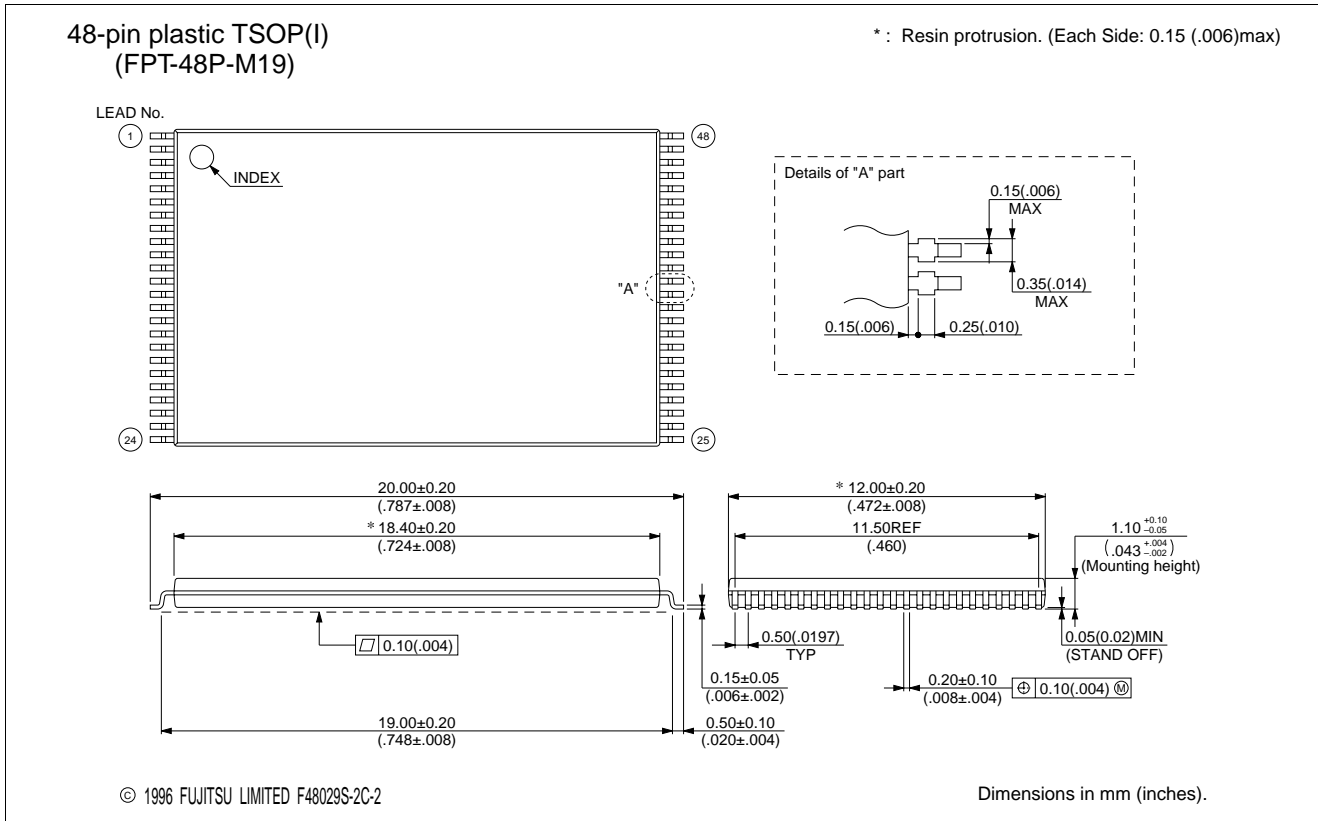

# FUJITSU LIMITED

*For further information please contact:*

## **Japan**

FUJITSU LIMITED  
Corporate Global Business Support Division  
Electronic Devices  
KAWASAKI PLANT, 4-1-1, Kamikodanaka  
Nakahara-ku, Kawasaki-shi  
Kanagawa 211-8588, Japan  
Tel: 81(44) 754-3763  
Fax: 81(44) 754-3329

<http://www.fujitsu.co.jp/>

## **North and South America**

FUJITSU MICROELECTRONICS, INC.  
Semiconductor Division  
3545 North First Street  
San Jose, CA 95134-1804, USA  
Tel: (408) 922-9000  
Fax: (408) 922-9179

Customer Response Center  
*Mon. - Fri.: 7 am - 5 pm (PST)*  
Tel: (800) 866-8608  
Fax: (408) 922-9179

<http://www.fujitsumicro.com/>

## **Europe**

FUJITSU MIKROELEKTRONIK GmbH  
Am Siebenstein 6-10  
D-63303 Dreieich-Buchsschlag  
Germany  
Tel: (06103) 690-0  
Fax: (06103) 690-122

<http://www.fujitsu-edc.com/>

## **Asia Pacific**

FUJITSU MICROELECTRONICS ASIA PTE LTD  
#05-08, 151 Lorong Chuan  
New Tech Park  
Singapore 556741  
Tel: (65) 281-0770  
Fax: (65) 281-0220

<http://www.fmap.com.sg/>

F9811

© FUJITSU LIMITED Printed in Japan

All Rights Reserved.

The contents of this document are subject to change without notice. Customers are advised to consult with FUJITSU sales representatives before ordering.

The information and circuit diagrams in this document are presented as examples of semiconductor device applications, and are not intended to be incorporated in devices for actual use. Also, FUJITSU is unable to assume responsibility for infringement of any patent rights or other rights of third parties arising from the use of this information or circuit diagrams.

FUJITSU semiconductor devices are intended for use in standard applications (computers, office automation and other office equipment, industrial, communications, and measurement equipment, personal or household devices, etc.).

### **CAUTION:**

Customers considering the use of our products in special applications where failure or abnormal operation may directly affect human lives or cause physical injury or property damage, or where extremely high levels of reliability are demanded (such as aerospace systems, atomic energy controls, sea floor repeaters, vehicle operating controls, medical devices for life support, etc.) are requested to consult with FUJITSU sales representatives before such use. The company will not be responsible for damages arising from such use without prior approval.

Any semiconductor devices have an inherent chance of failure. You must protect against injury, damage or loss from such failures by incorporating safety design measures into your facility and equipment such as redundancy, fire protection, and prevention of over-current levels and other abnormal operating conditions.

If any products described in this document represent goods or technologies subject to certain restrictions on export under the Foreign Exchange and Foreign Trade Law of Japan, the prior authorization by Japanese government will be required for export of those products from Japan.