

AKAI SERVICE MANUAL

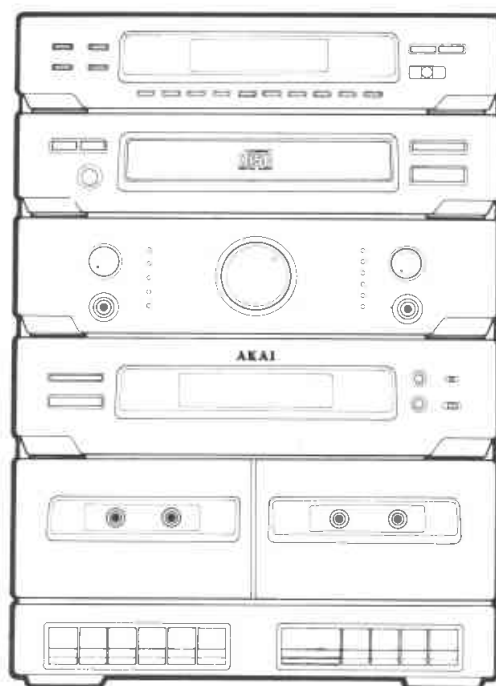

COMPACT
disc
DIGITAL AUDIO

MINI COMPONENT STEREO SYSTEM

MODEL **AC-MX90**

MODEL **AC-MX90/L**

SAFETY INSTRUCTIONS

PRECAUTIONS DURING SERVICING

1. Parts indentified by the Δ (*) symbol parts are critical for safety. Replace only with parts number specified.
2. In addition to safety, other parts and assemblies are specified for conformance with such regulations as those applying to spurious radiation. These must also be replaced only with specified replacements.
Examples: RF converters, tuner units, antenna selects switches, RF cables, noise blocking capacitors, noise blocking filters, etc.
3. Use specified internal wiring. Note especially:
 - 1) Wires covered with PVC tubing
 - 2) Double insulated wires
 - 3) High voltage leads
4. Use specified insulating materials for hazardous live parts. Note especially:
 - 1) Insulation Tape
 - 2) PVC tubing
 - 3) Spacers (Insulating Barriers)
 - 4) Insulation sheets for transistors
 - 5) Plastic screws for fixing microswitch (especially in turntable)

5. When replacing AC primary side components (transformers, power cords, noise blocking capacitors, etc.), wrap ends of wires securely about the terminals before soldering.
6. Observe that wires do not contact heat producing parts (heatsinks, oxide metal film resistors, fusible resistors, etc.).
7. Check that replaced wires do not contact sharp edged or pointed parts.
8. Also check areas surrounding repaired locations.
9. Use care that foreign objects (screws, solder droplets, etc.) do not remain inside the set.

SAFETY CHECK AFTER SERVICING

After servicing, make measurements of leakage-current or resistance in order to determine that exposed parts are acceptably insulated from the supply circuit.

The leakage-current measurement should be done between accessible metal parts (such as chassis, ground terminal, microphone jacks, signal-input/output connectors, etc.) and the earth ground through a resistor of 1500 ohms paralleled with a 0.15 μ F capacitors, under the unit's normal working conditions. The leakage-current should be less than 0.5 mA rms AC.

The resistance measurement should be done between accessible exposed metal parts and power cord plug prongs with the power switch (if included) "ON". The resistance should be more than 2.2 Mohms.

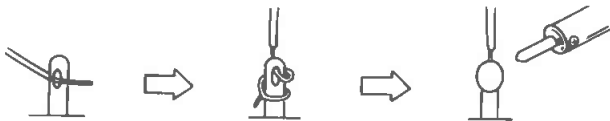

INFORMATION

SYMBOLS FOR PRIMARY DESTINATION

Alphabet indicates the destination of the units as listed below.

Symbols	Principal Destinations
A	USA
B	UK
C	Canada
E	Europe (except UK)
J	Japan
S	Australia
V	Italy only
U	Universal Area
Y*	Custom version

I. DISASSEMBLY

In case of trouble, etc., necessitating dismantling, please dismantle in the order shown in the illustrations. Reassemble in reverse order.

1-1 MAIN SET

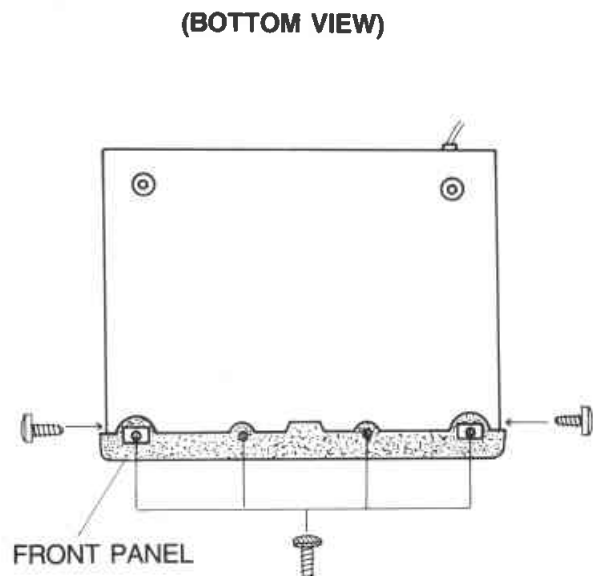
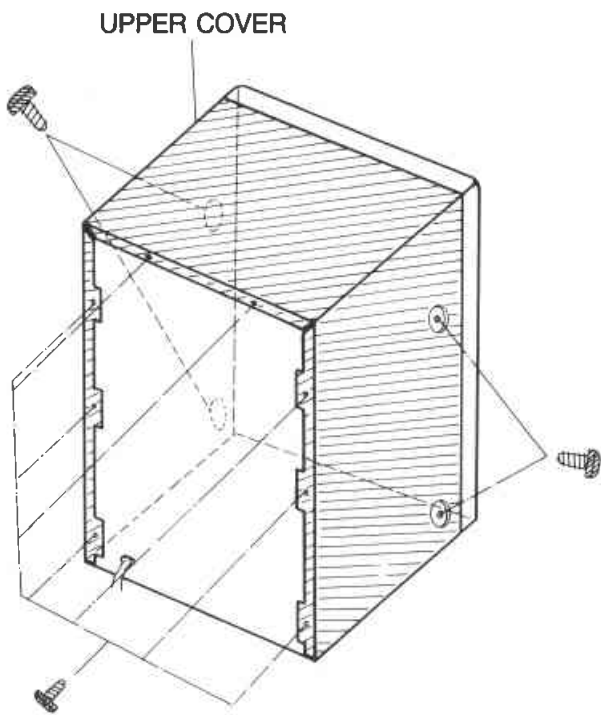

1-2 REMOTE

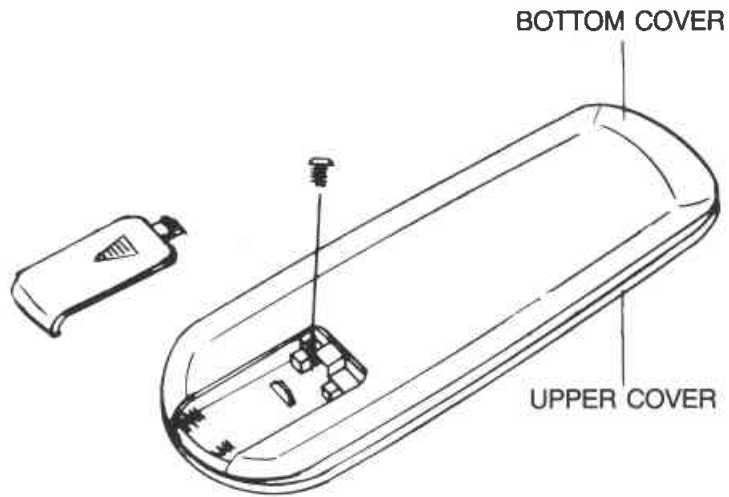

1-3 DISASSEMBLY PROCEDURES FOR CDP SECTION

REMOVING THE DISC TRAY

1. Apply Power Switch to the set and press the OPEN/CLOSE button to open the table load.
2. Apply OFF the Power Switch while the table load is open, and push the table load back in by hand to close it.
3. Pull out the table load by hand to open it again. The table load will disengage easily and come out smoothly.
4. Now remove the table load from the cabinet while pressing the hook in the direction of the arrow as shown Fig. 2

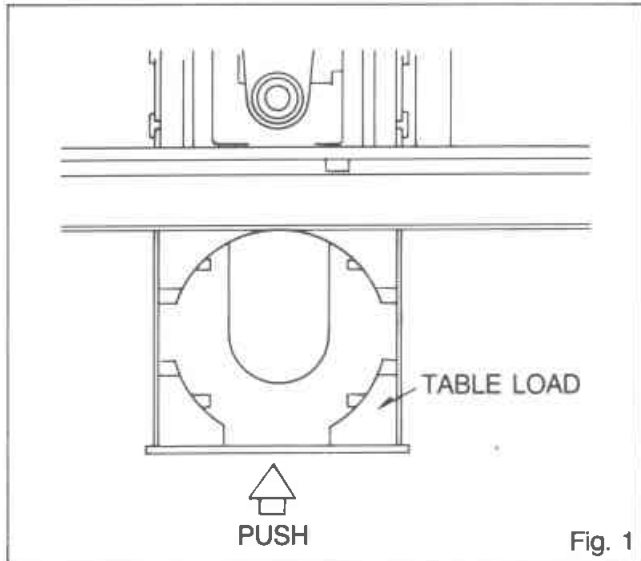

Fig. 1

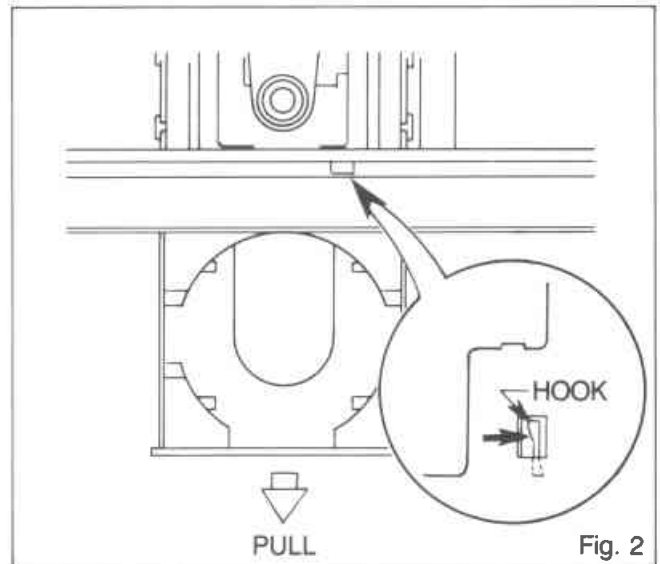

Fig. 2

REMOVING THE MECHANISM

Take out the four screws (1-4 in the diagram below) with which the mechanism is mounted in place and remove the mechanism.

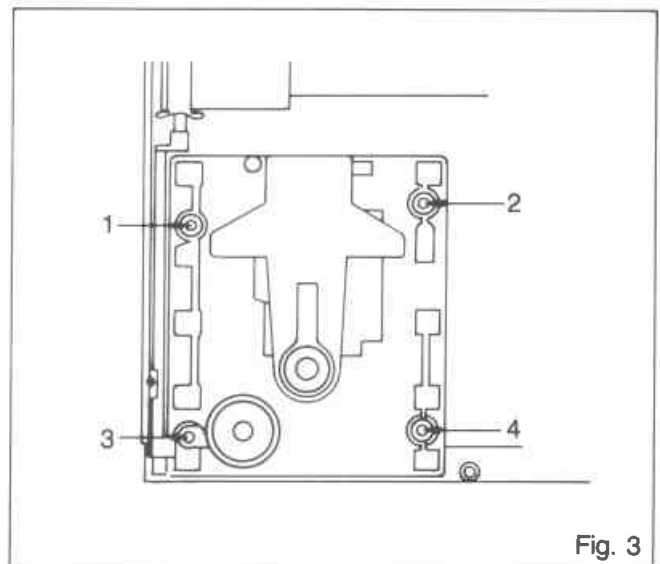

Fig. 3

II. SPECIFICATION

TUNER SECTION

Frequency range	: FM: 87.5 – 108.0 MHz (0.05 MHz steps) : MW (AM): 531 – 1602 KHz (9 KHz steps) : LW: 146 – 281 KHz (1 KHz steps) [E] [B]
Sensitivity	: FM: 3 μ V, MW (AM): 700 μ V, LW: 1500 μ V [E] [B]
Signal-to-noise ratio (IHF A Network)	: FM mono: 65 dB, FM stereo: 65 dB : MW (AM)/LW: 50 dB
Stereo separation	: 30 dB (1 KHz)

AMPLIFIER SECTION

Continuous output power	: 25 + 25 Watts RMS 1KHz THD 10% at 8 ohm
Frequency response	: 20 Hz – 40 KHz (\pm 3 dB)
Total harmonic distortion	: 0.05% (– 10 dB for RMS per channel power output at 8 ohm)
Input sensitivity	: AUX/VCR 400mV/50kohms, PHONO 5mV/47kohms

CASSETTE SECTION

Rec	: AC bias (100 KHz)
Erase	: AC erase
Wow and flutter	: 0.2%
Signal-to-noise ratio	: 55 dB
Frequency response	: Normal: 100 Hz – 10 KHz (\pm 3 dB) : CrO ₂ : 100 Hz – 12.5 KHz (\pm 3 dB)
Tape speed	: 4.75 cm/sec (Normal), 9.5 cm/sec (High)

CD SECTION

AUDIO CHARACTERISTICS

Frequency response	: 20 Hz – 20 KHz (\pm 1.5 dB)
Harmonic distortion	: Less than 0.07% (1 KHz)
S/N ratio	: More than 90 dB
Wow and flutter	: Below measurable limits
Channel separation	: More than 90 dB (1 KHz)

FUNCTIONS

Instant programme section	: Sequential, with F-Skip (▶▶I) and B-Skip (I◀◀) buttons
Fast-forward/back	: Fast-forward/back with sound
Remain time display	: With TIME button (during normal disc-play only)
Programme functions	: 20 selections
Repeat	: One track, all programmed tracks
Program reset	: Press STOP button twice (during programmed disc-play) or CLEAR button
Pause	: Each track
Disc loading	: Motor drive horizontal loading

DIGITAL SIGNAL PROCESSING

Optical pickup	: 3-beam laser (Semiconductor laser, $\lambda = 780\text{nm}$)
Error correction	: CIRC
Sampling frequency	: 44.1 KHz
D/A conversion	: 16-bit linear
Filter	: Digital filter + 4-pole LC filter

GENERAL

Power source	: AC 240V 50Hz [B] [S] : AC 220-230V/50 Hz [E] [V]
Dimensions	: 265(W) × 377(H) × 235(D) mm
Weight	: 8.9 Kg

III. PRINCIPAL PARTS LOCATION

(TOP VIEW)

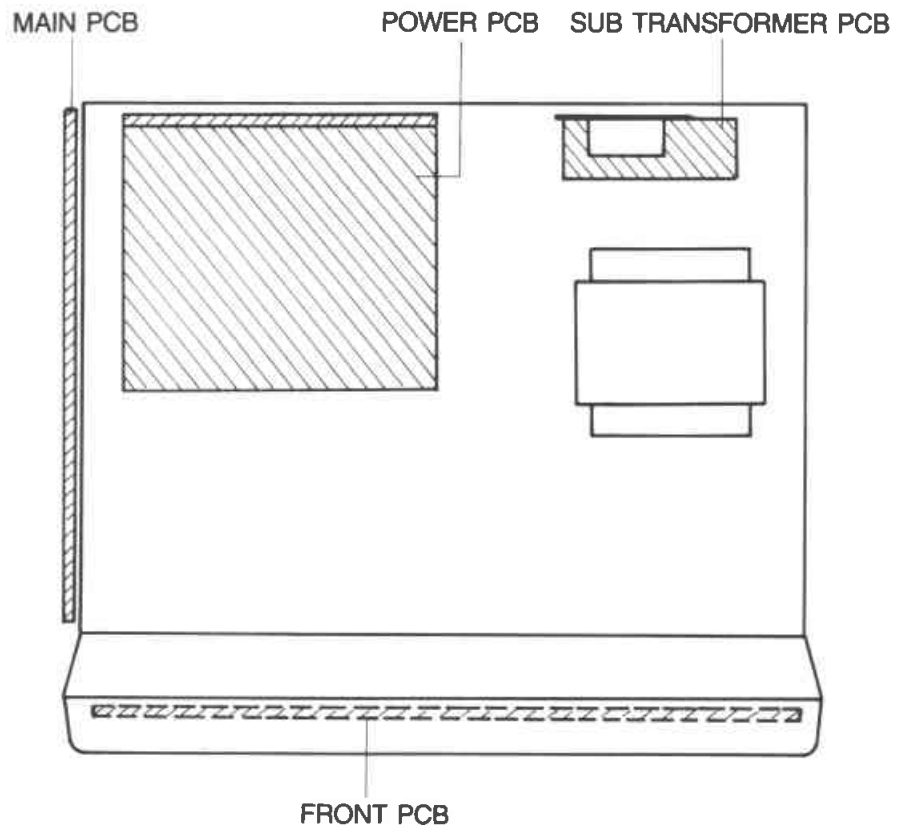

IV. ADJUSTMENT

4-1. TAPE

[PRECAUTIONS BEFORE ADJUSTMENT]

1. Before adjustment, clean and de-magnetize the heads and tape guides.
2. Set the switches as follows.
Dolby NR switch : OFF
3. Use the following recording test tapes.
NORMAL position: TDK AC-214
CrO₂ position : TDK AC-513
4. 0 dBs = 0.388V.

3 HEAD AZIMUTH ALIGNMENT (TAPE I & II)

1. 12.5KHz-15VU test tape (MTT-111DN)
2. PLAY
3. LINE OUT, HEAD AZIMUTH ALIGNMENT SCREW N
4. •Connect an AC milli-voltmeter to TP201.
*Maximum output level.

STEP	ADJUSTMENT ITEM
1.	TEST TAPE/INPUT SIGNAL
2.	MODE
3.	TEST POINT, ADJUSTMENT PART
4.	REMARKS (•) and RESULT (*)

ADJ. Part →

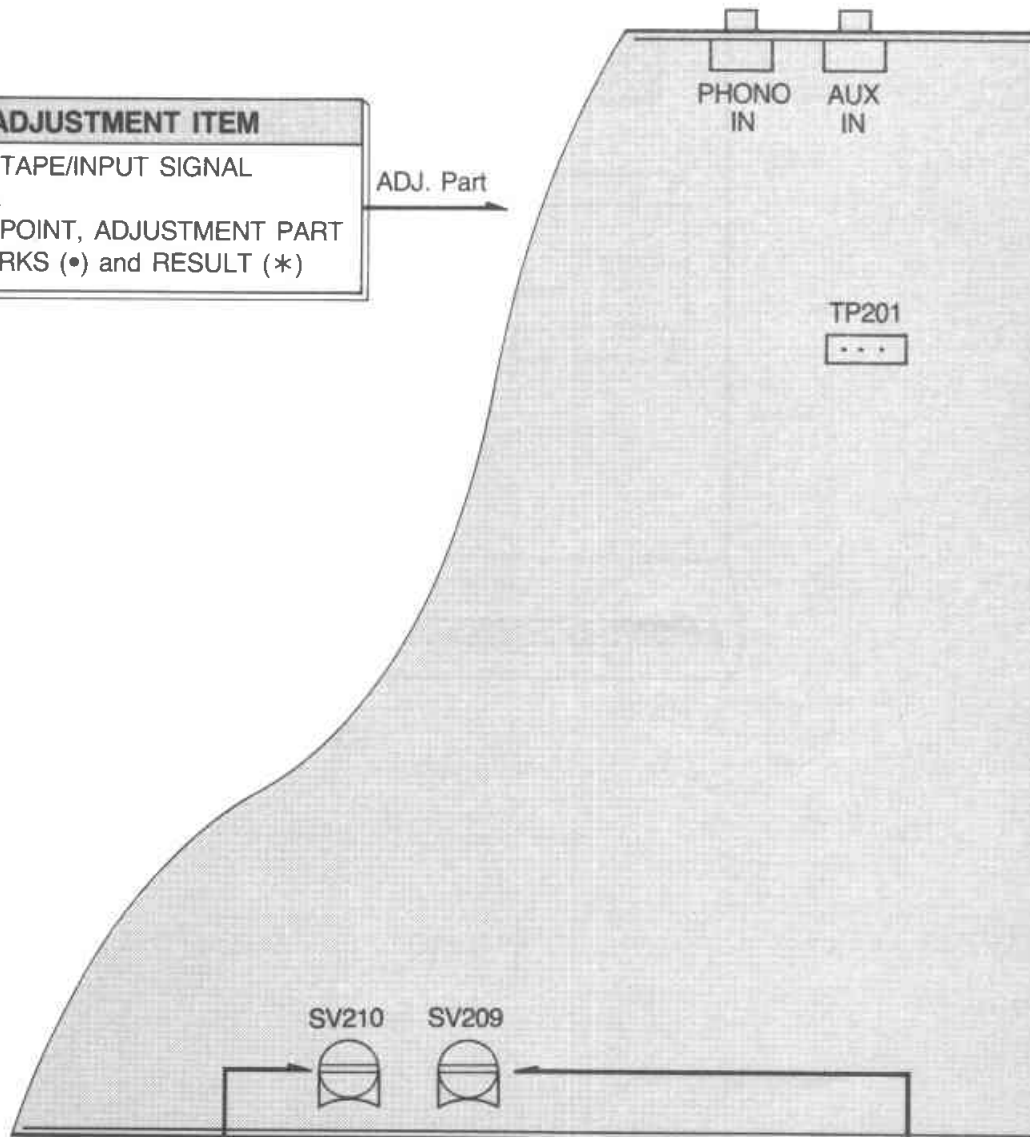

2 TAPE NORMAL SPEED
1. 3000 Hz test tape (MTT-111DN)
2. PLAY
3. TP201, SV210
4. •Connect a frequency counter to TP201. *3000 ± 10 Hz

1 TAPE HIGH (×2)
1. 3000 Hz test tape PI TAPE I (MTT-111DN)
2. TAPE I PLAY TAPE
3. TP201, SV209
4. •Connect a frequency counter to TP201 and REC AT 6000 ± 10Hz

IT
357G)
r to

6 OSC FREQUENCY (TAPE II REC/PB only)

1. No signal input, METAL recording test tape.
2. REC
3. TP202, T205
4. •Connect a frequency counter between TP202
* $100 \pm 0.5\text{KHz}$

11 TAPE II BIAS

1. 400Hz and 12.5KHz, 30mV (AUX IN)
2. REC → PLAY (PB)
3. TP201, SV207 (L-ch)/SV208 (R-ch)
4. •Connect an AC milli-voltmeter to TP201.
* Playback levels of 400 Hz and 12.5 KHz are equal or within $\pm 1.0\text{ dB}$

12 TAPE II REC LEVEL

1. NORMAL tape, 1 KHz, 125mV (AUX IN)
2. REC → PLAY (PB)
3. TP201, SV205 (L-ch)/SV206 (R-ch)
4. •Connect an AC milli-voltmeter to LINE OUT.

4 TAPE I PB LEVEL

1. 315 Hz test tape (MTT-150)
2. PLAY
3. TP201, SV203 (L-ch)/SV204 (R-ch)
4. •Connect an AC milli-voltmeter to TP201.
* 388mV ADJ

5 TAPE II PB LEVEL

1. 315 Hz test tape (MTT-150)
2. PLAY
3. TP201, SV201 (L-ch)/SV202 (R-ch)
4. •Connect an AC milli-voltmeter to TP201.
* 388mV ADJ

PEED
AY BACK AT
REC
counter to
APE II.

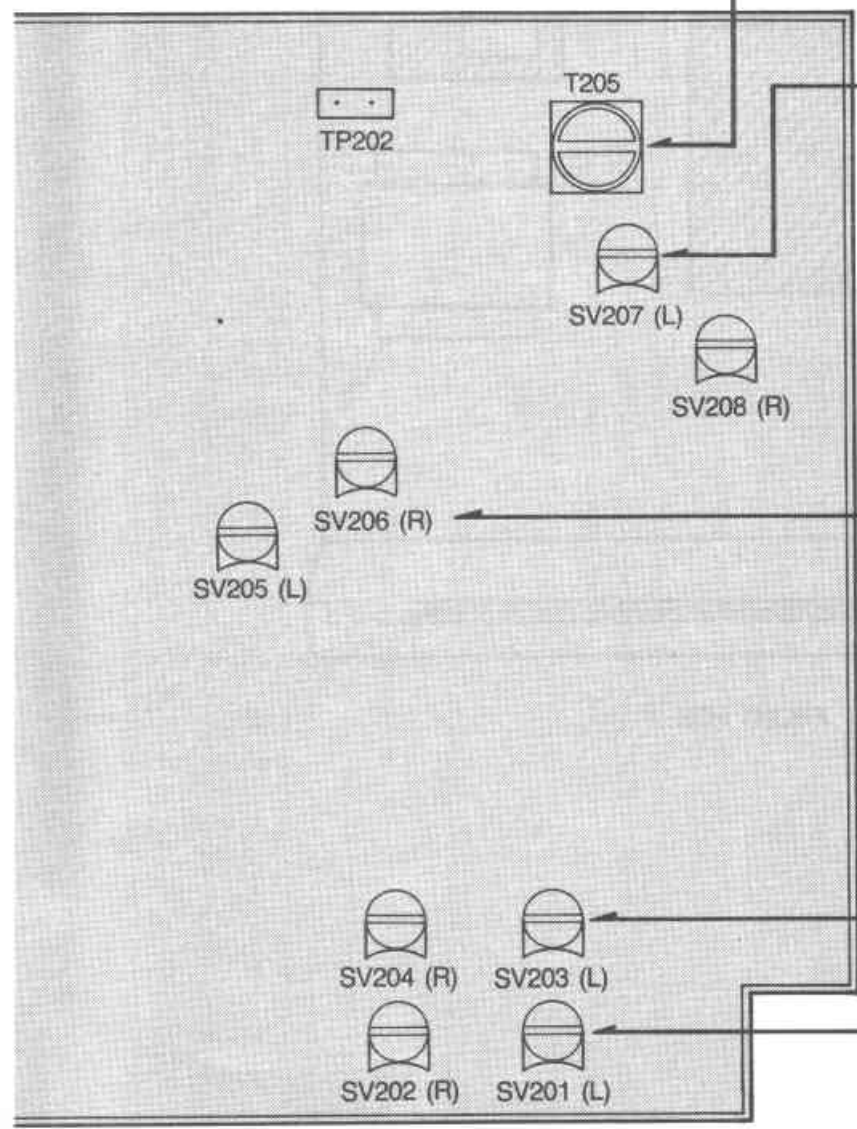

IV. ADJUSTMENT

4-2 TUNER

4-2-1 INSTRUMENT CONNECTIONS

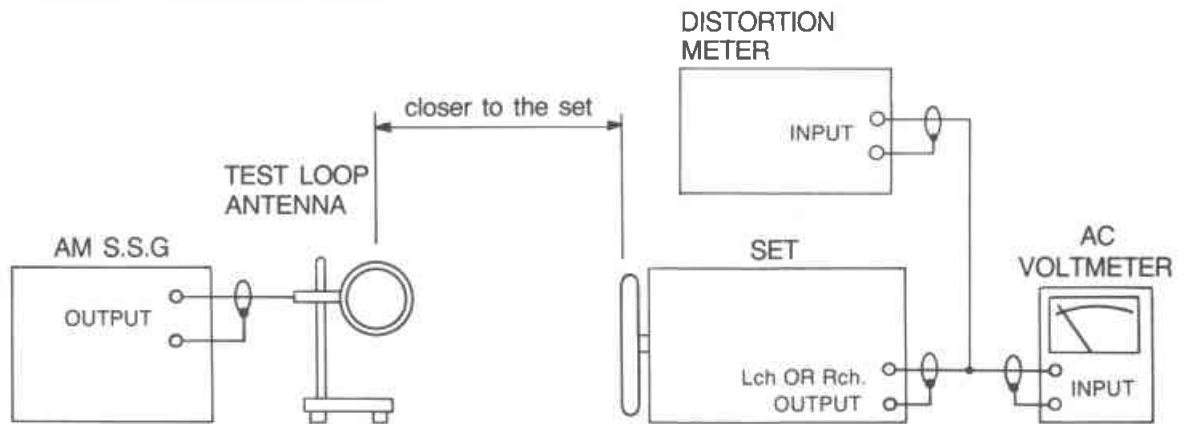

Fig. 4-1 Instrument connection for AM (MW, LW) section adjustment

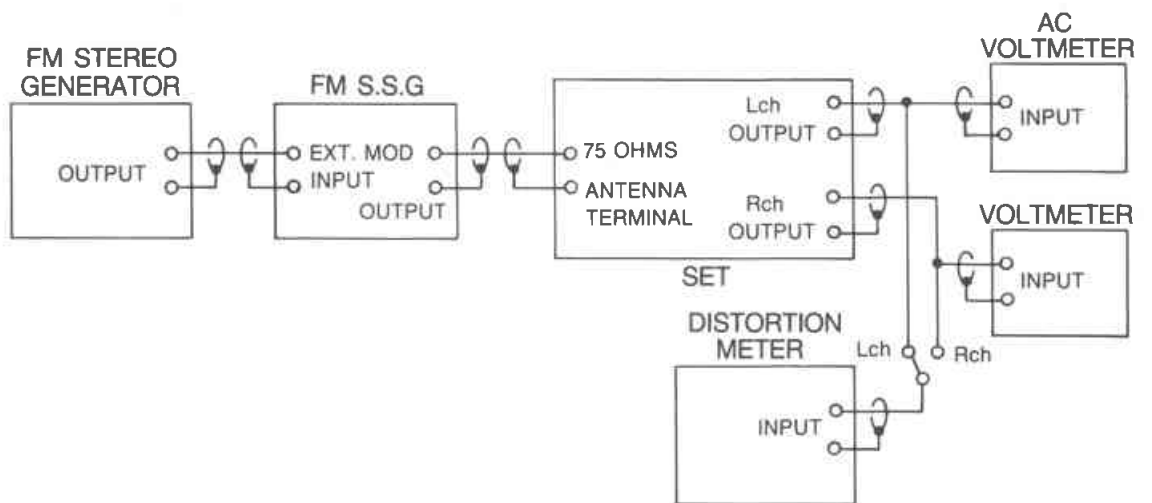

Fig. 4-2 Instrument connection for FM section adjustment

IV. ADJUSTMENT

4-2-2. ADJUSTMENT

STEP	ADJUSTMENT
1.	SSG FREQUENCY, OUTPUT LEVEL
2.	TUNING FREQUENCY
3.	TEST POINT, ADJUSTMENT PART
4.	REMARKS (*) and RESULT (*)

Adjustment part

Test point

FM/AM

FM

NOTE: Set the SSG to 1 KHz, 75 KHz deviation for **E**, **B**, **S**, model, 40 KHz deviation for **V** model.

2 FM SENSITIVITY

1. 90.0, 98.0, 106.0MHz 15dB μ
2. 90.0, 98.0, 160.0 MHz
3. TP105, BLACK IFT IV FRONT END
4. • Connect the THD METER both terminal of TP105.
* Adjust BLACK FT so that the reading on the THD METER is minimum distortion.

3 STEREO SEPARATION

1. 98.0 MHz, 60dB μ (STEREO L or R channel only)
2. 98.0 MHz
3. TP105, SV101
4. • Connect an frequency counter to R116 lead & GND.
* 76KHz

1 TUNED SENSITIVITY

1. 97.945, 97.750 MHz, 60 dB μ (AUTO)
2. 98.0 MHz
3. TP105, T104
4. • Connect the OSC 110 scope to TP105.
* Tuned indicator on at 97.950
Tuned indicator off at 97.945

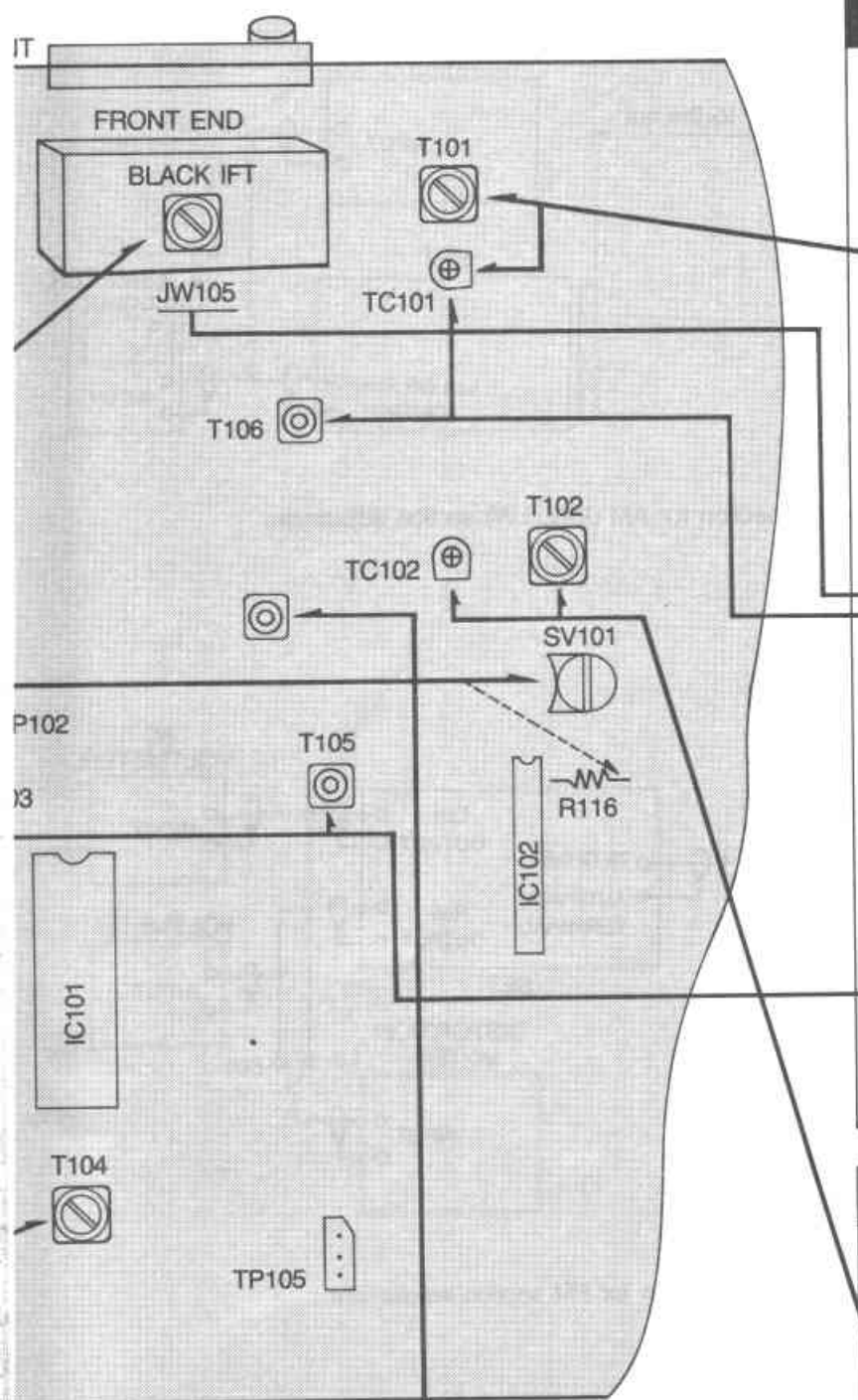

AM (MW)

NOTE: Set the SSG to 1 KHz, 30% modulation of each.

3 AM (MW) SENSITIVITY

1. 603KHz (LOW)*1404KHz (HIGH), 70dB μ .
2. 603 KHz (LOW)/1404 KHz (HIGH)
3. TP105, T101 (LOW)/TP101 (HIGH)
4. • Connect the AC milli-voltmeter to TP105.

* Maximum output level.

NOTE: For best result repeat LOW and HIGH adjustment several times.

1 AM (MW) TUNING VOLTAGE

- 1.
 2. 531 KHz (LOW)/1602 KHz (HIGH)
 3. T106 (LOW)/TC101 (HIGH).
 4. • Connect the digital DC voltmeter between JW105 and GND.
* LOW 1.03V/HIGH: 7.0 to 8.0V
- NOTE: For best result repeat LOW and HIGH adjustment several times.

2 AM IF

1. 603 KHz 74 dB μ
2. 603 KHz
3. TP105, T103, T105
4. • Connect the AC milli-voltmeter to TP105.
* Maximum output level.

LW

NOTE: Set the SSG to 1 KHz, 30% modulation of each.

2 LW SENSITIVITY

1. 160 KHz (LOW)/260 KHz (HIGH) 70dB μ
2. 160 KHz (LOW)/260 KHz (HIGH)
3. TP105, T102 (LOW)/TC102 (HIGH)
4. • Connect the AC milli-voltmeter to TP105.
* Maximum output level.

NOTE: For best result repeat LOW and HIGH adjustment several times.

1 TUNING VOLTAGE

- 1.
2. 146 KHz (LOW)/281 KHz (HIGH)
3. TP105, T107 (LOW)/TC102 (HIGH)
4. • Connect the digital DC voltmeter between TP105 and GND.

* Low: 1.0V/HIGH: 7.0 to 8.0V

NOTE: For best result repeat LOW and HIGH adjustment several times.

IV. ADJUSTMENT

4-3 CDP

STEP	ADJUSTMENT ITEM
1.	Test disc
2.	Mode
3.	Test Point & Adj. Part
4.	Result & Remarks

ADJ. Part

Test Point

2 E-F BALANCE

1. Test disc A-BEX TCD-791.
2. PLAY (TNO 4)
3. VR802
4. Connect an oscilloscope between "TE" of CN10 and GND then short between "T OFF" of CN10 and GND.
* Adjust VR802 so that center of waveform on the oscilloscope as shown below.

3 FOCUS SERVO GAIN

1. Test disc A-BEX TCD-791
2. PLAY (TNO4)
3. VR801
4. Connect an oscilloscope between "F COIL" of CN2 and GND.
* 0.6 to 1.0Vp-p

4 TRACKING SERVO GAIN

1. Test disc A-BEX TCD-791
2. PLAY (TNO4)
3. VR803
4. Connect an oscilloscope between pin TP3 and GND.
* 0.8 to 1.2 Vp-p

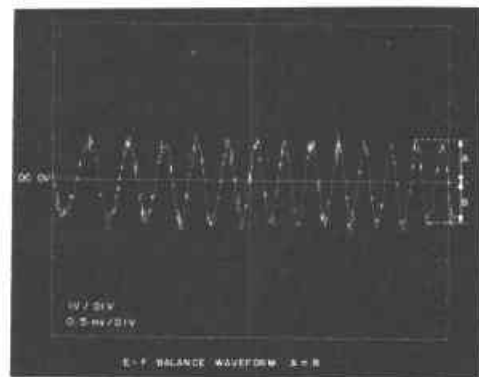
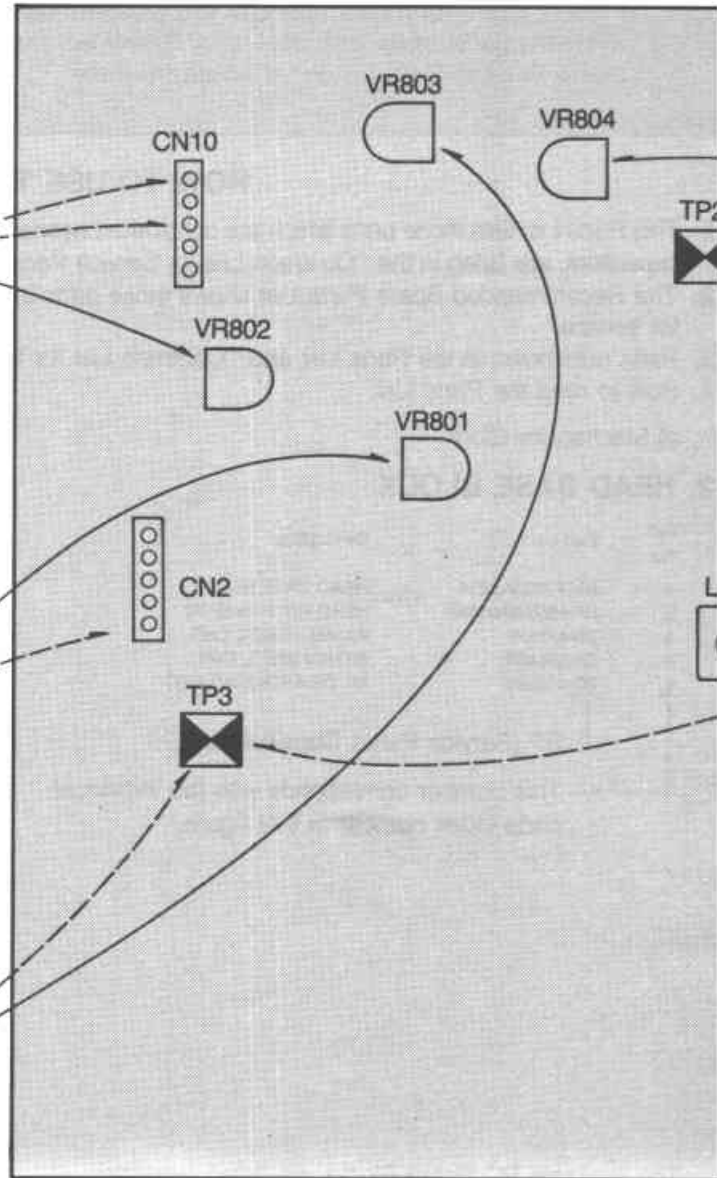

2

1 PLL

- 1.
2. STOP
3. Connect Frequency Counter to Test pin TP1.
4. Adjust L801 so that $4.4\text{MHz} \pm 50\text{KHz}$

5 TRACKING SERVO OFF-SET

- 1.
2. STOP
3. VR804
4. Connect on oscilloscope to test pin TP3, then short the test pin TP2 and GND.
* Adjust VR804 so that the center of waveform on the oscilloscope is DC $0\text{V} \pm 20\text{mV}$.

TP1

A2P-093



3

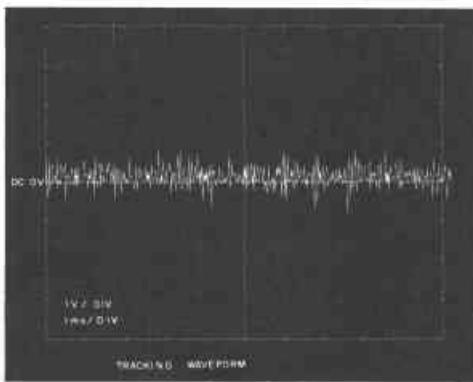

4

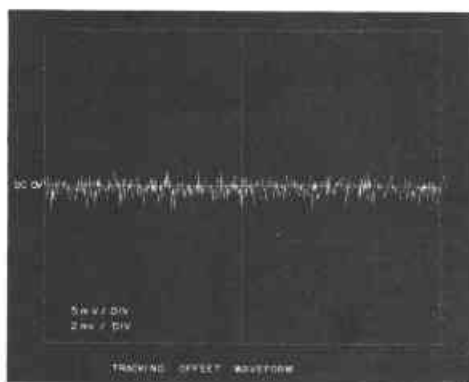

5

V. PARTS LIST

ATTENTION

1. When placing an order for parts, be sure to list Part No. Model No. and the description of eachpart. Otherwise, the non-delivery of the part or the delivery of a wrong part may result.
2. Please make sure that Part No. is correct when ordering. If not, a part different from the one you ordered may be delivered.
3. Since the parts shown in Parts List of Preliminary Service Manual may have been the subject of changes, please use this Parts List for all future reference.

HOW TO USE THIS PARTS LIST

1. This Parts List lists those parts which are considered necessary for repairs. Other common parts, such as resistors and capacitors, are listed in the "Common List for Service Parts" from which these parts should be selected and stocked.
2. The Recommended Spare Parts List shows those parts in the Parts List which are considered particularly important for service.
3. Parts not shown in the Parts List and "Common List for Service Parts" will not in principle be supplied.
4. How to read the Parts List.

a) Mechanism Block

b) PC Board

2. HEAD BASE BLOCK

Ref. No.	Part No.	Description
1	BH-T2023A320A	HEAD BASE BLOCK
2	HP-H2206A010A	HEAD R/P PR4-8FUC
3	ZS-477876	PAN20 x 03STL CMT
4	ZS-536488	BID20 x 08STL CMT
5	ZG-402895	SP CS ANGLE ADJUST

SP (Service Parts) Classification

This number corresponds with the individual parts index number in that figure.

6. MAIN P.C. BOARD

Ref. No.	Part No.	Description
IC1	EI-324536	IC HD14049BP
IC2	EI-336801	IC MB8841-564M
C1A	EC-338399	C MMY V 223M 250AC [U,E,B,S]
C1B	EC-350949	C MMY V 223M 250DC [J]
C1C	EC-338397	C MMY V 223M 125AC [C,A]
X1	EI-318384	OSC X'TAL NC-18C

Symbols for primary destination

[A]: AAL (U.S.A) [S]: SAA (Australia)
 [B]: BEAB (England) [U]: U/T (Universal Area)
 [C]: CSA (Canada)
 [E]: CEE (Europe) [V]: VDE (Italy)
 [J]: JPN (Japan) [Y]: Custom Version

SP (Service Parts) Classification

These reference symbols correspond with component symbols in the schematic diagrams.

The available PC Board Blocks are listed separately.

5. When Part No. is known, Parts Index at end of Parts List can be used to locate where that part is shown in Parts List by its Reference No. listed at right of Part No.

WARNING

(*) INDICATED SAFETY CRITICAL COMPONENTS. FOR CONTINUED SAFETY, REPLACE SAFETY CRITICAL COMPONENTS ONLY WITH MANUFACTURE'S RECOMMENDED PARTS.

AVERTISSEMENT

(*) IL INDIQUE LES COMPOSANTS CRITIQUES DE SÉCURITÉ. POUR MAINTENIR LE DEGRÉ DE SÉCURITÉ DE L'APPAREIL, NE REMPLACER QUE DES PIÈCES RECOMMANDÉES PAR LE FABRICANT.

V. PARTS LIST

1. RECOMMENDED SPARE PARTS

We suggest you to stock the following Recommended Spare Part items listed below since they can cover most of the routine service.

Ref. No.	Part No.	Description
1-1	PTAJ-00560-X46	TRANS-POW A74-056X-S (MAIN) [E] [V]
1-2	PTAJ-00560-Z4B	TRANS-POW A74-056Z-B [B], [S]
1-3	PTAJ-00560-A4V	TRANS-POW A74-056BX-V [U]
2-1	PTAC-00820-X46	TRANS-POW A35-082X-S (SUB) [E] [V]
2-2	PTAC-00820-Z4B	TRANS-POW A35-082Z-B [B], [S]
2-3	PTAC-00820-44V	TRANS-POW A35-082BX-V [U]
3	DECA-00183-001	MECHA-CASSETTE TN21ZSW-639
4	DECD-00072-00F	MECHA-CDP CDKM87TK3
5	ESRY-00010-120	RELAY HR703V DC12V
6	ESRY-00040-121	RELAY VS12SMCU5VD8 DC12V
7	FGFB-S1002-137	FUSE FST0034. 3117 250V T1A
8	FGFB-S6301-137	FUSE T 250V 630mA
9	FGFB-S8001-137	FUSE T 250V 800mA
10	DDTR-00020-SD0	D RECTIFIER IN4002 100V 1A
11	DDTS-00060-S00	D SI 1S131
12	DDTS-00040-S00	D SI 1S2472
13	DDSR-00190-T10	D GP20-02A 200V 2A
14	DDTS-00070-S00	D SI 1S133
15	DDSV-0003A-S30	D VVC 1SV149A AM
16	DDSV-00100-S10	D VVC SVC211 FM
17	TRTA-0008G-SD0	TR KTA1266-GR
18	TRTA-0012Y-SD0	TR KTA966A-Y
19	TRTA-0041E-SOS	TR DTA144E-S
20	TRTA-0042E-SOS	TR DTA124E-S
21	TRTC-0001B-SD0	TR KTC2878-B
22	TRTC-0008Y-SD0	TR KTC2120-Y
23	TRTC-0060E-SOS	TR DTC144E-S
24	TRTC-0061E-SOS	TR DTC124E-S
25	TRTC-0013Y-S30	TR 2SC2236-Y
26	TRTC-0008Y-SD0	TR KTC-2120Y
27	TRTA-0009Y-SD0	TR KTA1271-Y
28	TRTC-0016G-SD0	TR KTC3198-GR
29	TRSD-0008Y-SDB	TR KTD2058
30	TRTD-00200-SD0	TR KTD1302
31	TRTC-0010Y-SD0	TR KTC1923-Y
32	DDTZ-G0750-S00	D ZENER MTZ7.5B
33	DDTZ-G120C-S00	D ZENER MTZ12C
34	DDTZ-G056B-S00	D ZENER MTZ5.6
35	DDTZ-G082C-S00	D ZENER MTZ8.2C
36	DDTZ-G091B-S00	D ZENER MTZ9.1B
37	DPLA-00140-00L	LAMP 110mA 12V
38	DPLC-00100-00P	DISPLAY-LCD
39	DPLC-00090-00T	DISPLAY-LCD
40	DPLT-00352-DY2	D0T-DED DLA215-D
41	DPLT-00141-RC5	D0T-LED DLR503-T
42	DPLT-00141-YC5	D0T-LED DLY503-T
43	DPIR-00021-005	D0T-IR LED KLN 105B-B
44	ICRG-00170-SQ0	IC GL7909
45	ICDG-00140-S10	IC LC7520
46	ICLN-00870-S40	IC CXA1102
47	ICCM-00020-SQ0	IC GD4011B
48	ICDG-00140-S10	IC LC7520
49	ICDG-00560-SB0	IC BA6208
50	ICDG-00600-T90	IC S-8054 ALB
51	ICLN-00710-S90	IC M5229P
52	ICMP-00510-S20	IC uPD75108GF-R29-3BE
53	ICOP-00132-SE0	IC KA4558S
54	ICOP-00131-SE0	IC MC4558C

Ref. No.	Part No.	Description
55	ICCM-00170-SQ0	IC GD4052B
56	ICDG-00370-S20	IC uPD1330HA
57	ICLN-00540-SB0	IC BA3416BL
58	ICHP-00090-S10	IC STK4132-II
59	ICRG-00160-SE0	IC MC7809C
60	ICRG-00190-SE0	IC MC7912C
61	ICRG-00217-SE0	IC MC7812C
62	ICDG-00460-S30	IC TC9227P
63	ICLN-00070-SD0	IC KIA7343P
64	ICLN-00100-SD0	IC KIA7758P
65	ICHY-00070-SS0	IC GPIU 701R
66	ICMP-00170-S30	IC TC9306F-027BS
67	ICMP-00500-S10	IC LC5864H-1435
68	ICDG-00151-S10	IC LC7860KA
69	ICDG-00470-SQ0	IC GM76C28-10
70	ICDG-00590-SE0	IC KDA0316
71	ICLN-00720-S10	IC LA9200NM
72	ICRG-00030-SD0	IC KTA 79L006P 6V
73	ICRG-00040-SE0	IC MC7805C
74	ICMP-00220-S20	IC uPD6122G-001
75	KTRE-00090-040	REASONATOR CST4. 00MGW
76	KTRE-00060-004	REASONATOR CSB455E 455KHz
77	KTAL-00010-086	CRYSTAL HC-49/U 8.6436MHz
78	KTAL-00040-072	CRYSTAL HC-49/U 7.2MHz
79	KTRE-00030-041	REASONATOR CSA4. 19MG
80	SWPU-00071-019	SW PUSH SPEA122SC011
81	SWSL-00376-042	SW SLIDE KSA2340B
82	SWTA-00120-060	SW TACT KHH10910L0
83	SWSL-00128-012	SW SLIDE 00120050
84	VRAE-C017B-503	VR RK12K 1130-50KB
85	VRAE-D019W-104	VR RK12K 1170-100KW
86	VWBD-F001B-104	VR RK14112MA-100K3 2
87	KIML-00020-E20	COIL-FM MPX FILTER AMA-002
88	KIAT-00350-E20	COIL-AM ANT AAT-035 MW
89	KIAT-00300-E20	COIL-AM ANT AAT-030 LW
90	KIAO-00250-E20	COIL-AM OSC AAO-025 LW
91	KIAO-00240-E20	COIL-AM OSC AAO-024 AM
92	IFFD-00070-E20	IFT-FM DET AFD-007
93	IFAD-00040-E20	IFT-AM DET AAD-004
94	IFAA-00130-E20	IFT-AM AAA-013
95	KIBK-00090-E20	COIL-AUDIOCHOKE ABK009
96	KIRO-00140-E10	COIL-REC OSC ARO-014
97	KIRA-00090-E20	COIL-REC TRAP ARA-009
98	KIRP-00050-E20	COIL-REC TRAP ARP-005
99	RFUW-F2R2J-120	R-FUSIABLE 1/4W 2.2 ohm
100	RFUS-G100J-130	R-FUSIABLE 1/2W 10 ohm
101	RFUW-F560J-120	R-FUSIABLE 1/4W 56 ohm
102	RFUM-F4R7J-120	R-FUSIABLE 1/4W 4.7 ohm
103	RFUZ-F470J-001	R-FUSIABLE 1/4W 47 ohm
104	TUFF-00110-00D	FRONT-END SE-1030H4
105	BTCE-00040-107	FILTER-CERAMIC SFE 10.7 MS2A
106	BTCE-00092-107	FILTER-CERAMIC SFE 10.7 MA5 L-A
107	BTCE-00130-004	FILTER-CERAMIC SFU 450B
108	CACS-U472M-039	C-AC DE 7150F 472 MVA1 KC 400V

V. PARTS LIST

CASSETTE MECHA BLOCK (TN-21ZSW-639)

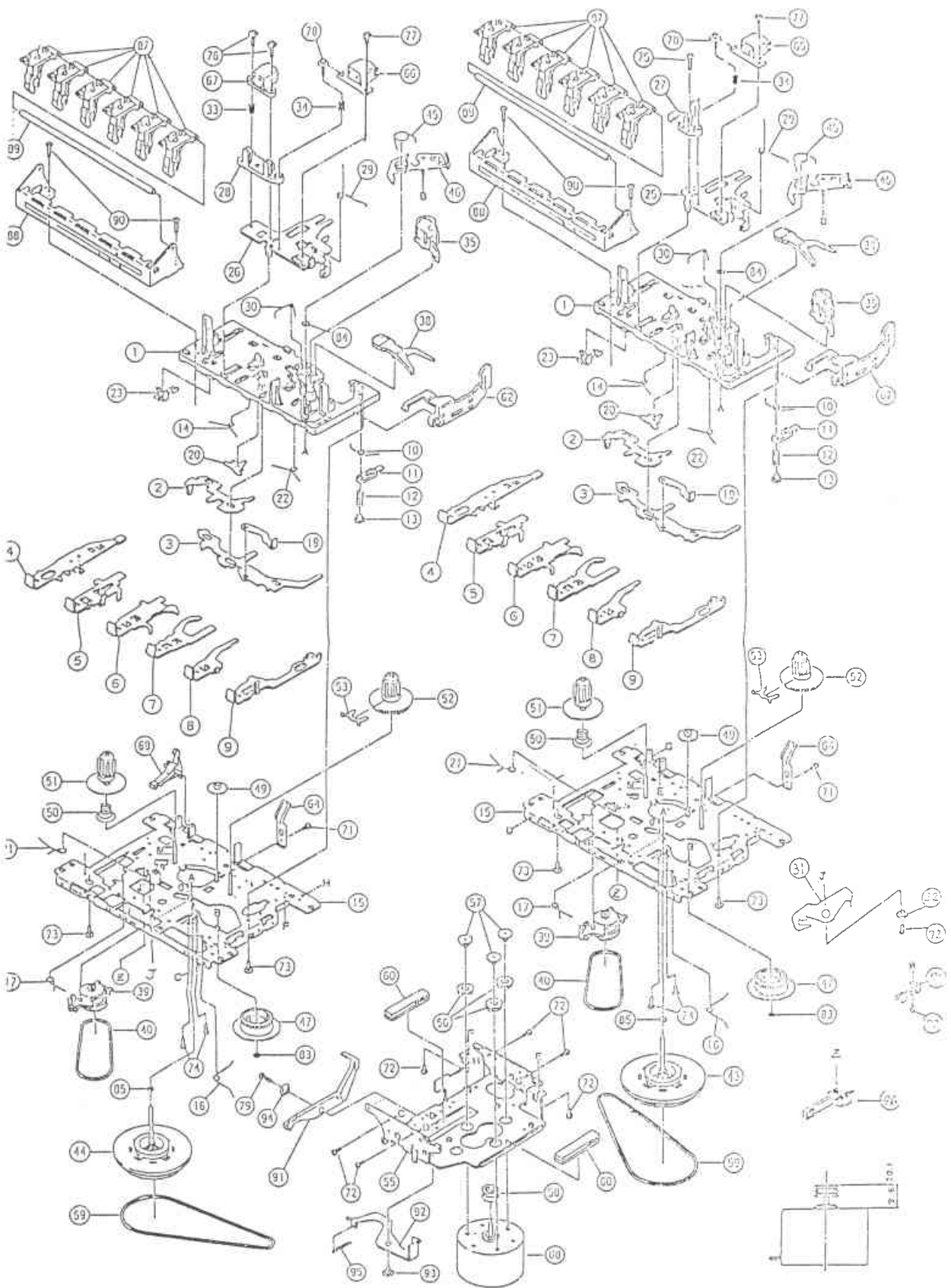

V. PARTS LIST

2. MECHA BLOCK (TAPE DECK)

Ref. No.	Part No.	Description	Ref. No.	Part No.	Description
1	1921 14 301	BASE ASS'Y	77	9115 00 00	+ BIND SCREW M2×3
2	1921 14 09	SWITCH ACTUATOR	78	9922 00 00	C TAPPING SCREW M2×6
3	1921 14 08	PUSH BUTTON ACTUATOR	83	9422 00 00	P WASHER CUT 1.2×3.8×0.3
4	1921 14 22	REC BUTTON LEVER	84	9999 03 13	P WASHER CUT 1.45×3.8×0.5
5	1921 14 23	PLAY BUTTON LEVER	85	9786 00 00	P WASHER 2×3.5×0.3
6	1921 14 24	REW BUTTON LEVER	87	1821 31 07	OPERATION LEVER
7	1921 14 25	FF BUTTON LEVER	88	1821 31 06	BUTTON FRAME (S)
8	1921 14 26	STOP BUTTON LEVER	89	1829 31 03	BUTTON LEVER SHAFT
9	1921 14 13A	PAUSE BUTTON LEVER	90		S TAPPING SCREW (FOR CAM- ERA)
10	1921 14 13A	P CONTROL SPRING		9999 14 02	M2×8 (GUIDE)
11	1921 14 55	PAUSE LEVER (E)	91	1921 12 09	P KICK LEVER(B)
12	1921 14 12	PAUSE LEVER SPRING	92	1821 12 68	P KICK LEVER (A)
13	1921 14 11	PAUSE STOPPER	93	1821 12 23	PK COLLER SCREW (A)
14	1921 14 14	BUTTON LEVER SPRING (A)	94	1821 12 65	COLLER (B)
15	1921 01 501	CHASSIS ASS'Y	95	1821 12 25	P KICK LEVER SPRING
16	1921 14 16	E ACTUATOR SPRING	96	6401 01 161	LEAF SWITCH MSW-17820
17	1921 14 17	P.S. LEVER SPRING	97	6401 01 38	LEAF SWITCH MSW-1275
19	1821 01 159	E KICK LEVER	98	6401 01 125	LEAF SWITCH MSW-1664
20	1921 14 20	PR STOPPER	99	9661 00 00	CAP TAPPING SCREW 2×5
21	1921 14 21	REC BUTTON LEVER SPRING			
22	1921 14 15	BUTTON LEVER SPRING (B)			
23	6401 01 149	LEAF SWITCH MSW-1541T			
25	1921 03 01	HEAD PANEL			
26	1921 03 02	HEAD PANEL			
27	1921 03 04	HEAD BASE			
28	1921 03 06	HEAD BASE			
29	1021 03 03	PANEL P SPRING			
30	1921 14 18	M CONTROL SPRING			
31	1921 02 01	REC ARM			
32	1921 14 34	P ARM COLLAR			
33	1821 03 08	EH SPRING			
34	1821 03 07	AZIMUTH SPRING			
35	1921 04 301	PINCH ROLLER ARM ASS'Y			
38	1921 26 04	SENSING LEVER			
39	1921 07 302	RF CLUTCH ASS'Y			
40	1921 07 03	RF BELT			
43	1921 09 304	FLYWHEEL ASS'Y			
44	1921 09 303	FLYWHEEL ASS'Y			
45	1921 26 05	GEAR PLATE SPRING			
46	1921 26 501	GEAR PLATE ASS'Y			
47	1921 26 02	CAM GEAR			
49	1821 10 70	FF GEAR			
50	1829 10 10	BACK TENSION			
51	1921 05 304	SUPPLY REEL ASS'Y			
52	1921 05 305	TAKE UP REEL ASS'Y			
53	1921 05 06	SENSOR			
55	1921 12 11	MOTOR BRACKET			
56	1820 13 06	MOTOR RUBBER			
57	1821 12 02	MOTOR COLLER SCREW			
58	1921 12 13	MOTOR PULLEY			
59	1821 12 22	MAIN BELT			
60	1921 12 12	ANTI VIBRATION FELT MAT			
62	1921 13 02	EJECT SLIDE LEVER			
64	1829 10 01	PACK SPRING			
65		P HEAD MS15R-AA2NI			
66		R.P. HEAD MS15R-AA2NI			
67		E HEAD E-321PL-0201			
68		MOTOR EG-530YD-2B			
69	1821 10 69	RECORD SAFETY LEVER			
71	9179 00 00	C TAPPING SCREW M2×3			
72	9180 00 00	C TAPPING SCREW M2×4			
73	9679 00 00	P TAPPING BING. SCREW M2× 5			
74		TAPPING SCREW (FOR CAM- ERA) M2×45			
75	9004 00 00	SCREW M2×6			
76	9621 00 00	+ - CAP SCREW M2×8			

V. PARTS LIST

CD MECHA BLOCK

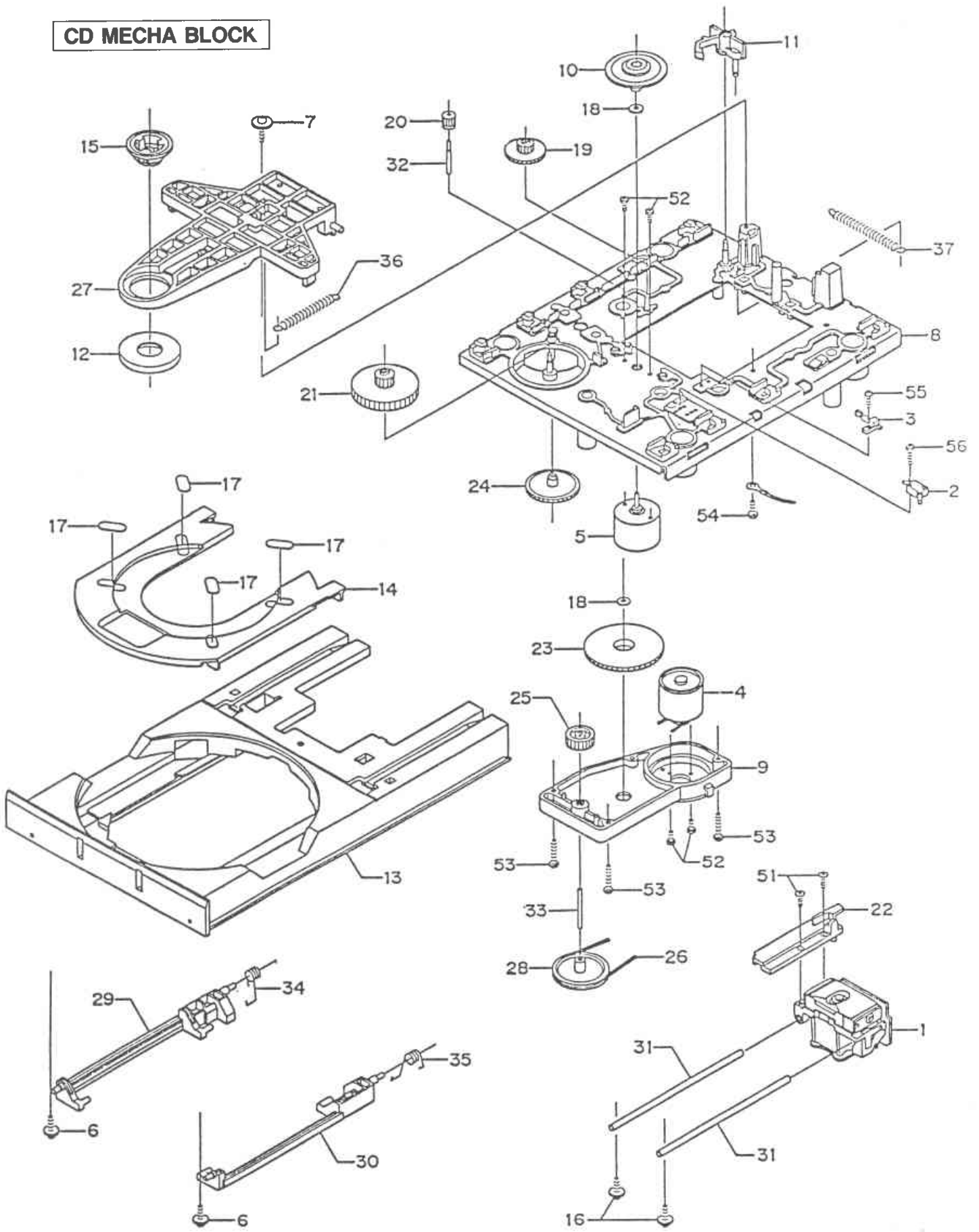

V. PARTS LIST

3. MECHA BLOCK C.D.P (CDKM-87TK3)

Ref. No.	Part No.	Description	Ref. No.	Part No.	Description
	14122729071000	WIRE BAND	D602		
1	1EA0A41A01300	PICK UP ASSY(SF-90)	D603		
2	42312070100	LEVER SW 1PIT	D604		
3	42319741700	LEAF SW		DDTR-00020-SD0	D RECTIFIER 1N4002
4	45279717610	MOTOR	D605		
5	45279718200	MOTOR	D606		
6	13124201282010	SCREW(B TITE SEMS)	D607		
7	13124201283000	SCREW(B TITE SEMS)Z	D608		
8	14103119286000	CHASSIS ASSY	D609		
9	14103129031000	CHASSIS SUB ASSY	D610		
10	14105229003000	TURNTABLE ASSY	D611		
11	14105559087000	ARM ASSY	D612		
12	14108619003000	MAGNET ASSY	D613		
13	14121149647020	TABLE LORD	D614		
14	14121149648000	TABLE CD	D615		
15	14123519838000	HOLDER DISK	D616		
16	14124219427000	SCREW WASHER	D617		
17	14124459513000	PAD DISK(FELT)	D618		
18	14124539143000	WASHER	D619		
19	14125519818000	GEAR PICK UP	D620		
20	14125519819000	GEAR MOTOR	D621		
21	14125519822000	GEAR TABLE LOAD		DDTS-00040-S00	
22	14125519823000	GEAR PICK UP RACK	D622		1S2472
23	14125519878000	GEAR LOAD UP	D625		
24	14125519879000	GEAR LOAD T.L	D626		
25	14125519880000	GEAR	D627		
26	14125649336000	BELT	D628		
27	14126229020000	FLAP DISK CRAMP	ZD601	DDTZ-G120C-S00	ZENER MTZ12C
28	14126619086000	PULLEY			RELAY HR-703V
29	14127429122000	LEVER HOLD DISK L	RY602	ESRY-00010-120	RELAY VS12SMCU5VD8
30	14127429123000	LEVER HOLD DISK R			FUSE FST0034. 3117
31	14127519883000	SHAFT PICK UP	RY601	ESRY-00040-121	FUSE T 250V 630mA
32	14127519884000	SHAFT GEAR S	F601	FGFB-S1002-137	
33	14127519912000	SHAFT PULLEY		FGFB-S6301-137	
34	14128529529000	SPRING LEVER LEFT	F604		
35	14128529530000	SPRING LEVER RIGHT	F605		
36	14128549438000	SPRING FLAP DISK CR		FGFB-S8001-237	FUSE T 250V 800mA
37	14128549439000	SPRING ARM	F602		
	14125229013000	TURNTABLE	F603		
	14124219367000	SET SCREW V CONE 2x4	IC601	ICHP-00090-S10	IC HYBRID AMP POWER STK4132II
51	SE3FN205R0SA-	FLT PCS 2x5	IC602	ICRG-00040-SE0	IC REGULATOR MC7805C
52	SE3PN173R0SM-	PAN PCS 1.7x3	IC606	ICRG-00160-SE0	IC REGULATOR MC7809C
53	SFBAN26140SE-	S-TPG BRZ 2.6x14	IC605	ICRG-00170-SQ0	IC REGULATOR GL7909
54	SFBAN306R0SE-	S-TPG BRZ 3x6	IC603	ICRG-00190-SE0	IC REGULATOR MC7912C
55	SFBPN206R0SE-	S-TPG PAN 2x6	IC604	ICRG-00217-SE0	IC REGULATOR MC7812C
56	ST3PN17100SM-	TPG PAN 2x6	L601	KIBK-00050-E40	COIL AUDIO CHOCK ABK005 2.2μH
			L602		
			PT601	PTAC-00820-X46	TRANSFORMER POWER A35-082X S
				RCMS-JR22K-410	R CEMENT 2W 0.22ohm
			R619		
			R620		
			R640	RFUS-G100J-130	R FUSIBLE 1/2W 10ohm
			R638	RFUW-F2R2J-120	RESISTOR FUSIBLE
			R639		1/4W 2.2ohm
			R616	RFUW-F560J-120	R FUSIBLE 1/4W 56ohm
			R615	RFUZ-F470J-001	R FUSIBLE 1/4W 47ohm

4. P.C BOARD BLOCK

Ref. No.	Part No.	Description
1	PCSU-00860-21B	POWER P.C BOARD A2U-086
2	PCSU-00460-11B	FRONT P.C BOARD A1U-046
3	PCSU-00450-11B	MAIN P.C BOARD A1U-045
4	(PCSP-00930-21B)	C.D.P P.C BOARD (A2P-093)
5	PCPU-01540-C5B	LED P.C BOARD A4U-154
6	PCPE-01470-41B	REMOTE P.C BOARD A4E-147

5. POWER P.C BOARD

Ref. No.	Part No.	Description
C651	CACS-U472M-039	AC DE7150F472MVA1 KC 400V
D601	DDSR-00190-T10	RECTIFIER GP20-02A (200V 2A)

V. PARTS LIST

Ref. No.	Part No.	Description
R643	RMOH-H4R7J-03F	R METAL OXIDE
R646		1W 470ohm
JK601	TESP-00010-08P	TERMINAL SPEAKER
		AU8 2021
Q601	TRSD-0008Y-SDB	TR KTD2058-Y W/MICA
Q613	TRTA-0008G-SD0	TR KTA1266-GR
Q614		
Q604	TRTA-0009Y-SD0	TR KTA1271-Y
Q603	TRTA-0012Y-SD0	TR KTA966A-Y
Q608		
Q609	TRTA-0041E-SOS	TR DTA144E S
Q612	TRTC-0001B-SD0	TR KTC2878 B
Q615		
Q616		
Q611	TRTC-0008Y-SD0	TR KTC2120 Y
Q602	TRTC-0013Y-S30	TR 2SC2236 Y
Q605	TRTC-0016G-SD0	TR KTC3198-GR
Q606		
Q607		
Q610	TRTC-0060E-SOS	TR DTC144E S

6. FRONT P.C BOARD

Ref. No.	Part No.	Description
D501	DDTR-00020-SD0	D RECTIFIER
D502		1N4002
D503	DDTS-00040-S00	D SI
D504		1S2472
D507		
D509		
D510		
D511		
D512		
D514		
D515		
D516		
D517		
D518		
D519		
D520		
D521		
D522		
ZD532	DDTZ-G082C-S00	D ZENER
		MTZ8.2C
ZD531	DDTZ-G091B-S00	D ZENER
		MTZ9.1B
LP501	DPLA-00140-00L	LAMP
LP502		110mA 12V
LP503		
LP504		
LCD501	DPLC-00090-00T	DISPLAY LCD
		HDL7332-5A2P02GA
LCD502	DPLC-00100-00P	DISPLAY LCD
		HDL 7333 5A6R022A
LD506	DPLT-00141-RC5	DOT-LED
LD507		DLR-503T
LD508		
LD509		
LD510		
LD511		
LD512		
LD501	DPLT-00141-YC5	DOT-LED
LD502		DLY-503T
LD503		
LD504		
LD505		
LD514	DPLT-00362-RR2	DOT-LED
		DLR 215D
IC504	ICDG-00560-SB0	IC MOTOR DRIVER
		BA6208

Ref. No.	Part No.	Description
IC505	ICDG-00600-T90	IC VOLTAGE DETECTOR
		S-8054 ALB
M501	ICHY-00070-SS0	IC REMOTE RECEIV
		GPIU 701R
IC501	ICMP-00170-S30	IC MICRO PROCESSOR
		TC9306F-027BS
IC503	ICMP-00500-S10	IC UCOMPUTER
		LC5864H 1435
IC502	ICMP-00510-S20	IC UCOMPUTER
		uPD75108GF R29-3BE
X501	KTAL-00040-072	CRYSTAL
		HC-49/U 7.2MHZ
X502	KTRE-00030-041	RESONATOR
		CSA4.19MG
X503	KTRE-00090-040	RESONATOR
		CST4.00MGW
R530	RMOH-H101J-030	R METAL OXIDE
		1W 100ohm
R533	RMOH-H391J-03F	R METAL OXIDE
R534		1W 390ohm
JK501	SKPH-00162-66W	SOCKET PHONE
JK502		HTJ064 04A
SW501	SWPH-00071-019	SWITCH-PUSH
SW502		SPEA122SC011
SW503	SWSL-00376-042	SWITCH SLIDE
		KSA 2340B
S501	SWTA-00120-060	SWITCH TACT
		KHH10910L0
S502		
S503		
S504		
S505		
S506		
S507		
S508		
S509		
S510		
S512		
S513		
S514		
S515		
S516		
S517		
S518		
S522		
S523		
S524		
S525		
S526		
Q501	TRTC-0016G-SD0	TR
Q502		KTC3198 GR
Q503		
VR502	VRAE-C008W-104	VR ROTARY
		RK12K11700T1 14W
VR501	VRAE-C017B-503	VR-ROTARY
		RK12K1130 50KB
VR503	VWBD-F001B-104	VR W/MOTOR
		RK14112MA-100KB X2

7. MAIN P.C BOARD

Ref. No.	Part No.	Description
BF101	BTBP-00011-BPM	FILTER-MICA PRINT
		BPMB6A
CF101	BTCE-00040-107	FILTER CERAMIC
		SFE 10.7MS2A
CF103	BTCE-00092-107	FILTER CERAMIC
		SFE 10.7MA5L-A
CF102	BTCE-00130-004	FILTER CERAMIC
		SFU 450B
C147	CENS-J1R0M-C10	C E/LOW LEAK
		50V 1uF

V. PARTS LIST

Ref. No.	Part No.	Description	Ref. No.	Part No.	Description
D108	DDTR-00020-SD0	D RECTIFIER	T102	KIAT-00300-E20	COIL-AM ANT
D109		1N4002			AAT030 LW
D101	DDTS-00070-S00	D SI	T101	KIAT-00350-E20	COIL-AM ANT
D102		*SS133			AAT035 MW
D103			L201	KIBK-00090-E20	COIL AUDIO CHOCK
D104			L202		ABK009 8.2mH
D105			T108	KIML-00020-E20	COIL-FM MPX FILTER
D106			T109		AMA002 19KHz
D107			L203	KIRA-00090-E20	COIL REC FILTER
D110			L204		ARA009 100KHz
D111			T205	KIRO-00140-E10	COIL REC OSC
D112					ARO014
D113			T201	KIRP-00050-E20	COIL REC TRAP
D202			T202		ARP005
D203			T203		
D204			T204		
D205			RN301	NERX-J0047-105	NETWORK RESISTOR
D206			RN302		RGLD7 105J 1M x 7
D207					
D208			R239	RFUM-F4R7J-120	R FUSIBLE
D209					1/4W 4.7ohm 5%
D210			R2C8	RMOH-H390J-030	R METAL OXIDE
D211					1W 39ohm
D212			JK301	SKRC-00022-040	SOCKET-RCA
D213					AP4-0032B
D214			S201	SWSL-00128-012	SWITCH-SLIDE
D215					00120050
D216			JK101	TEAT-00051-03R	TERMINAL ANTENNA
D217					AK1/2-1058A
D218			Q243	TRSD-0008Y-SDB	TR
D219					KTD2058 Y
D301			Q106	TRTA-0008G-SD0	TR
D302			Q108		KTA1266-GR
D303			Q111		
ZD301	DDTZ-G056B-S00	D ZENER MTZ5.6B	Q117		
ZD302			Q119		
ZD303			Q218		
ZD101	DDTZ-G0750-S00	D ZENER MTZ7.5	Q270		
IC205	ICCM-00020-SQ0	IC GD4011B	Q204	TRTA-0042E-SOS	TR
IC206			Q213		DTA124E-S
IC302	ICCM-00170-SQ0	IC 4CH MUX/DEMUX	Q217		
IC303		GD4052B	Q219		
IC307	ICDG-00140-S10	IC VOLUME	Q246		
		LC7520	Q251		
IC201	ICDG-00370-S20	IC TAPE SELECTOR	Q254		
		uPD1330HA	Q256		
IC103	ICDG-00460-S30	IC PLL PRESCAL	Q259		
		TC9227P	Q261		
IC102	ICLN-00070-SD0	IC PLL FM MPX	Q104	TRTC-0001B-SD0	TR
		KIA7343P	Q105		KTC2876 B
IC101	ICLN-00100-SD0	IC AM/FM IF SYSTEM	Q203		
		KIA7758P	Q257		
IC202	ICLN-00540-SB0	IC 2CH PRE AMP	Q260		
		BA3416BL	Q242	TRTC-0008Y-SD0	TR
IC305	ICLN-00710-S90	IC 7BAND EQ			KTC2120-Y
IC306		M5229P	Q112	TRTC-0010Y-SD0	TR
IC203	ICLN-00870-S40	IC DOLBY			KTC1923 Y
		CXA1102P	Q101	TRTC-0016G-SD0	TR
IC301	ICOP-00131-SE0	IC DUAL OP AMP	Q102		KTC3198-GR
IC304		MC4558C	Q107		
IC204	ICOP-00132-SE0	IC DUAL OP AMP	Q109		
		KA4558S	Q110		
T103	IFAA-00130-E20	IFT-AM	Q113		
		AAA013	Q114		
T105	IFAD-00040-E20	IFT-AM DET	Q115		
		AAD004	Q118		
T104	IFFD-00070-E20	IFT-FM DET	Q201		
		AFD007	Q202		
T106	KIAO-00240-E20	COIL-AM OSC	Q205		
		AAO024 MW	Q206		
T107	KIAO-00250-E20	COIL-AM OSC	Q207		
		AAO025 LW			

V. PARTS LIST

Ref. No.	Part No.	Description
Q208		
Q209		
Q210		
Q211		
Q212		
Q215		
Q220		
Q221		
Q222		
Q223		
Q224		
Q225		
Q226		
Q227		
Q228		
Q229		
Q230		
Q231		
Q232		
Q233		
Q234		
Q235		
Q236		
Q237		
Q238		
Q239		
Q240		
Q241		
Q244		
Q245		
Q247		
Q255		
Q263		
Q266		
Q120	TRTC-0060E-SOS	TR
Q216		DTC144E S
Q248		
Q249		
Q250		
Q262		
Q264		
Q265		
Q267		
Q268		
Q269		
Q214	TRTC-0061E-SOS	TR
Q252		DTC124E S
Q253		
Q258		
Q271		
FE101	TUFF-00110-00D	FRONT END
		SE-1030H4
TC101	VCTC-00022-300	TR IMMER
TC102		CVCN06C300
SV210	VFAB-A005B-102	R SEMI FIXED
		RH0615C 1KB
SV201	VFAB-A005B-103	SEMI FIXED
SV202		RH0615C100 10KB
SV203		
SV204		
SV207	VFAB-A005B-104	R SEMI FIXED
SV208		RH0615C100 100KB
SV209	VFAB-A005B-222	R SEMI FIXED
		RH0615C100 2.2KB
SV101	VFAB-A005B-472	R SEMI FIXED
		RH0615C100 4.7KB
SV205	VFAB-A005B-473	R SEMI FIXED
SV206		RH0615C100 47KB

8. C.D.P P.C BOARD

Ref. No.	Part No.	Description
VC801	DDSV-00100-S10	D VVC SVC211
DB01	DDTS-00060-S00	D SI 1S131
DB02		
DB03		
DB04		
DB05		
DB06		
DB07		
DB08		
DB11		
ZD801	DDTZ-G075B-S00	D ZENER
		MTZ7.5B
ZD802	DDTZ-G082C-S00	DIODE ZENER
ZD803		MTZ8.2C
IC803	ICDG-00151-S10	IC D.S.P LC7860KA
IC805	ICDG-00470-SQ0	IC CMOS RAM
		GM76C28
IC806	ICDG-00590-SE0	IC 16BIT D/A CONVERTOR
		KDA0316
IC804	ICLN-00720-S10	IC A.S.P
		LA9200NM
IC807	ICOP-00130-SE0	IC MC4558S
IC808		
IC809		
IC810		
IC802	ICRG-00030-SD0	IC KIA 79L006P
IC801	ICRG-00040-SE0	IC MC7805C
L801	KIRO-00290-E10	COIL REC OSC
		ARO029
X801	KTAL-00010-086	CRYSTAL
		HC 49/U 8.6436MHZ
Q801	TRTA-0008Y-SD0	TR KTA1266 Y
Q802		
Q804		
Q809	TRTA-0012Y-SD0	TR KTA966A Y
Q810		
Q813		
Q814		
Q807	TRTC-0001B-SD0	TR KTC2878 B
Q816		
Q817		
Q803	TRTC-0016Y-SD0	TR KTC3198 Y
Q806		
Q808	TRTC-0039Y-SD0	TR KTC2236A Y
Q811		
Q812		
Q815		
Q818	TRTD-00200-SD0	TR KTD1302
Q819		
VR801	VFAB-A005B-103	R SEMI FIXED
		RH0615C100 10KB
VR802	VFAB-A005B-104	R SEMI FIXED
		RH0615C100 100KB
VR804	VFAB-A005B-223	R SEMI FIXED
		RH0615C100 22KB
VR803	VFAB-A005B-473	R SEMI FIXED
		RH0615C 100 47KB

V. PARTS LIST

11. FINAL ASSEMBLY

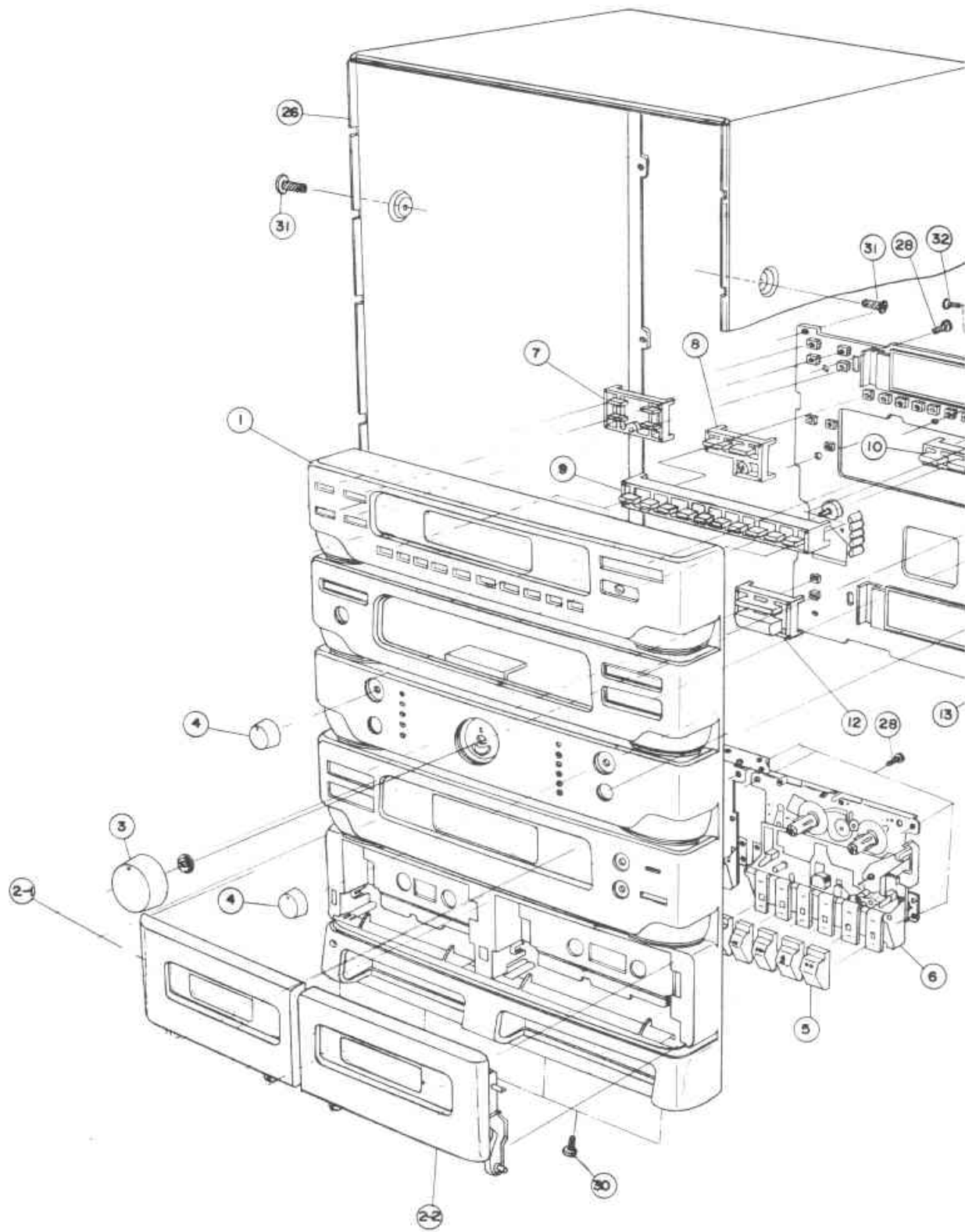

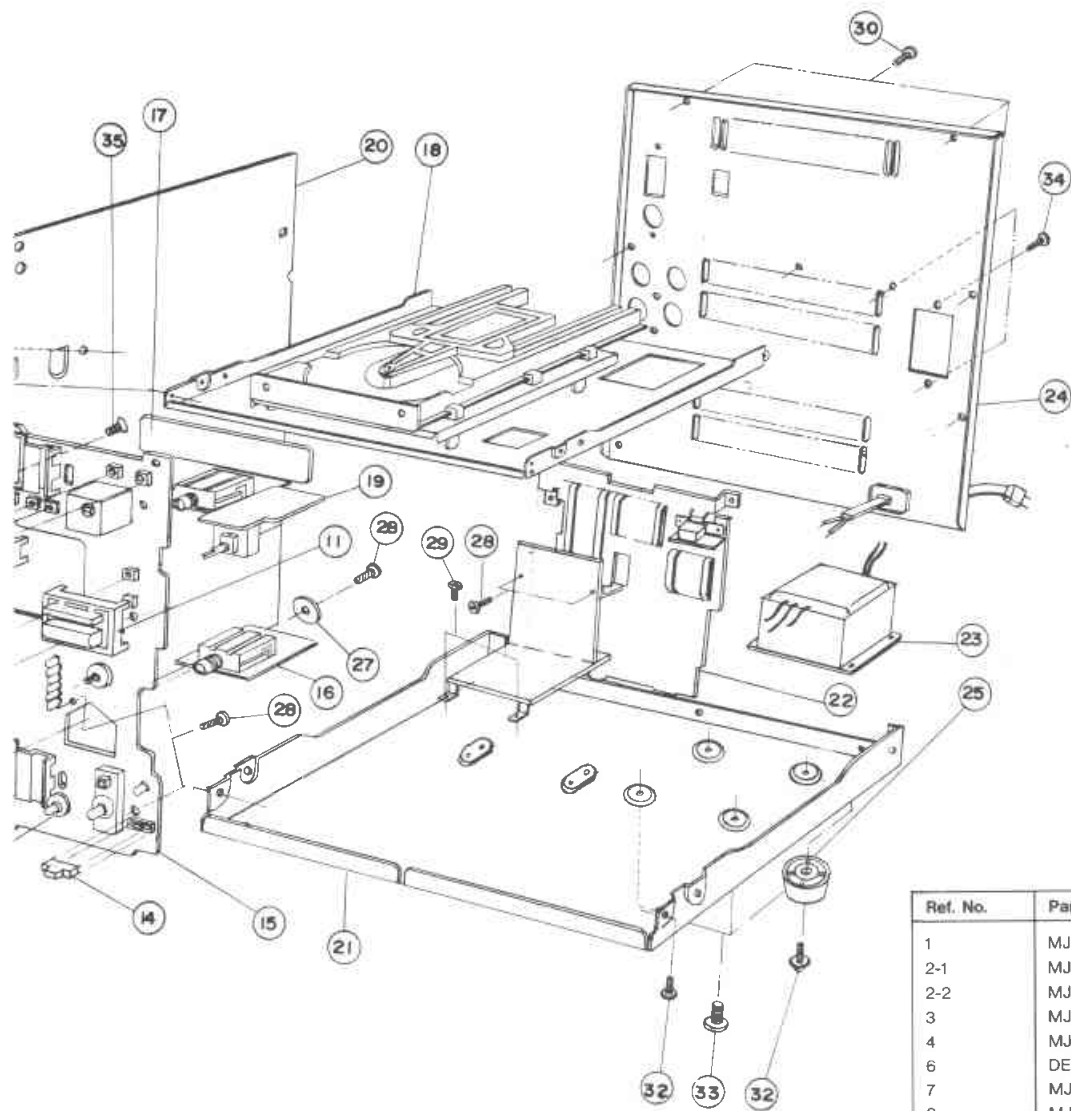

Ref. No.	Part No.	Description
1	MJAF-01760-ZZ1	PANEL-FRONT ASS'Y
2-1	MJAF-01380-ZZ2	DOOR-CAST-L ASS'Y
2-2	MJAF-01390-ZZ2	DOOR-CAST-R ASS'Y
3	MJAF-07760-ZZ4	KNOB-VOLUME
4	MJAF-07750-ZZ4	KNOB-BALANCE
6	DECA-00183-001	MECHA-DECK
7	MJAF-02930-ZZ3	KNOB-BAND
8	MJAF-02920-ZZ3	KNOB-CDP
9	MJAF-02940-ZZ3	KNOB-PRESET
10	MJAF-07650-ZZ4	KNOB-TUNING
11	MJAF-02910-ZZ3	KNOB-CDS
12	MJAF-02950-ZZ3	BUTTON-POWER
13	MJAF-07740-ZZ4	KNOB-SURROUND
14	MJAF-07770-ZZ4	KNOB-SLIDE
17	MJAF-02900-ZZ3	DOOR-CD
18	DECA-00270-002	CDKM87 TK3
21	MPAC-01960-002	CHASSIS BOTTOM
23	PTAJ-00560-X46	POWER TRANCE
24	MPAC-01940-ZZ2	CHASSIS-BACK
25	MRAG-00350-004	FOOT
26	MPAC-01930-ZZ2	CABINET TOP
27	PL PC 3×14×1T	WASHER PLAIN
28	BHT2T3×10 FE-ZY	SCREW TAPPING
29	BHT2T3×6 FE-ZY	SCREW TAPPING
30	BHT2T3×6 FE-ZB	SCREW TAPPING
31	BHT2T4×8 FE-ZB	SCREW TAPPING
32	BHT2T3×8 FE-ZY	SCREW TAPPING
33	BHM4×10 FE-ZY	SCREW TAPPING
34	BHT2T3×8 FE-ZB	SCREW TAPPING
35	FHT2T3×8 FE-ZB	SCREW TAPPING

VI. BLOCK DIAGRAM

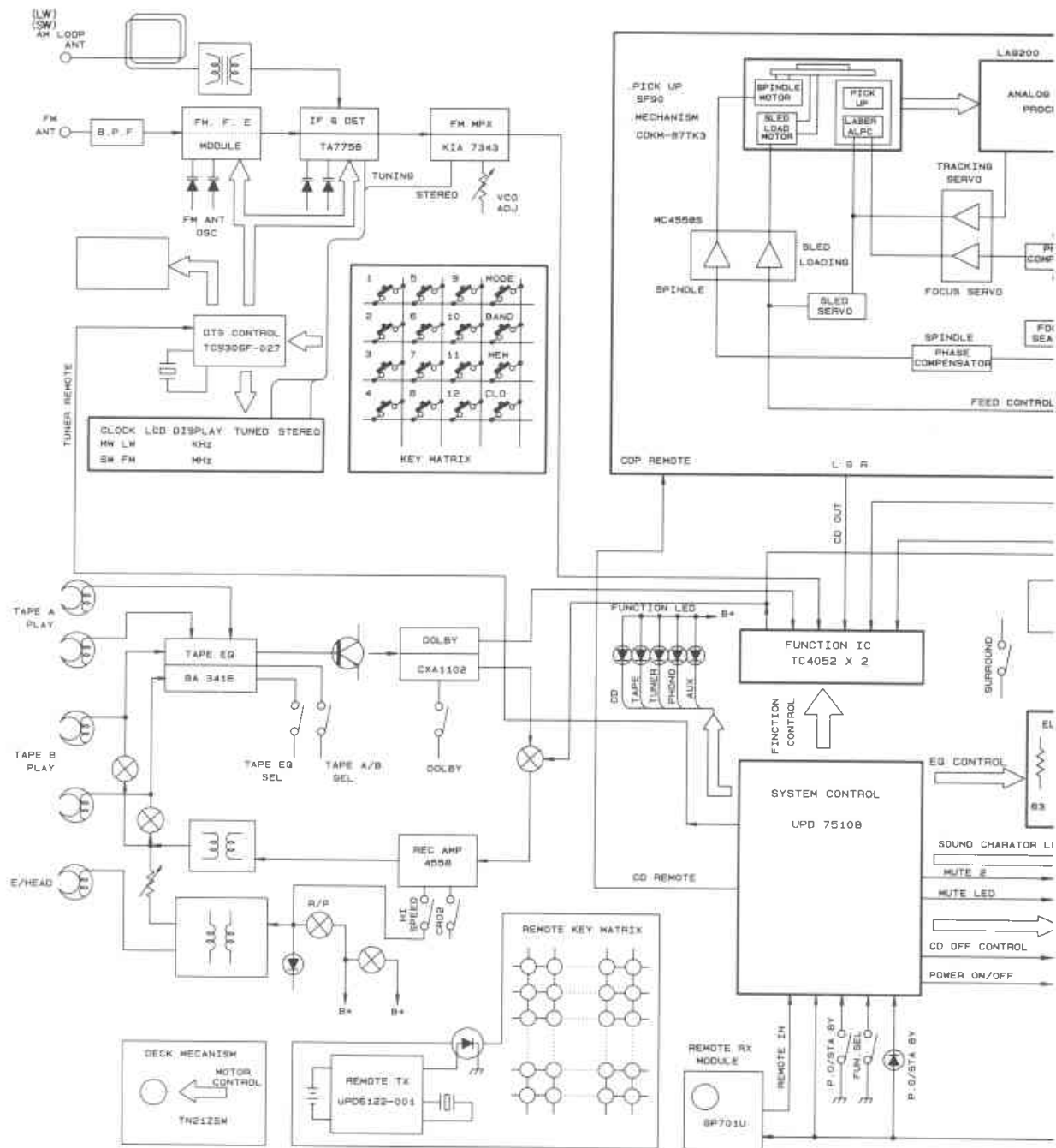

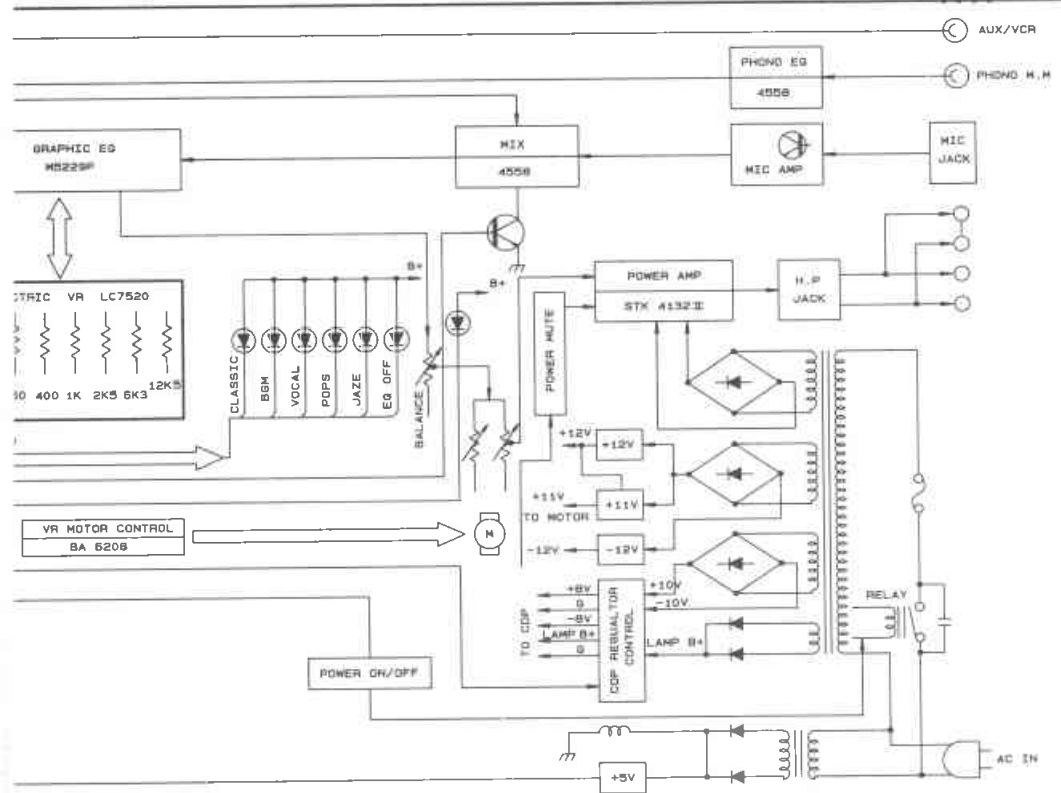
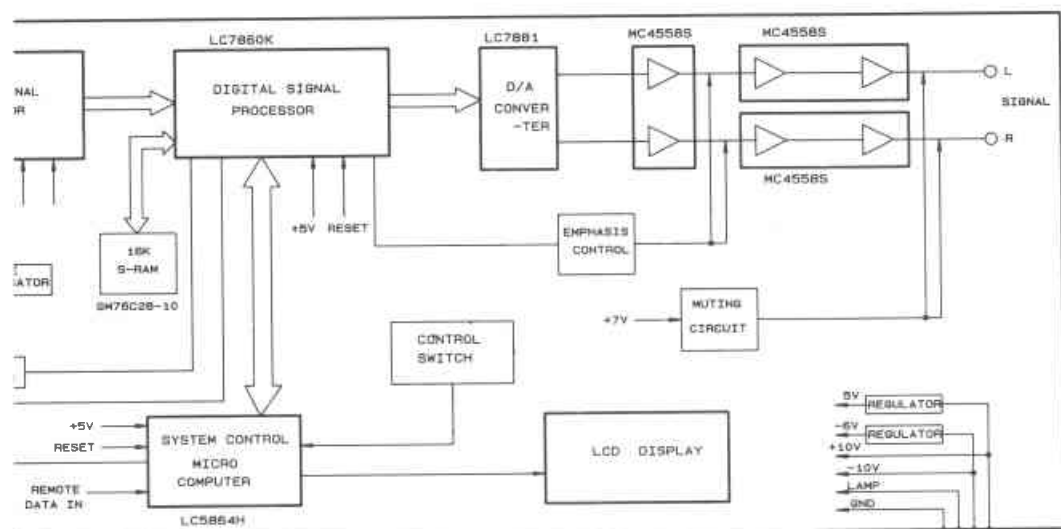

V. PARTS LIST

REMOTE ASSEMBLY

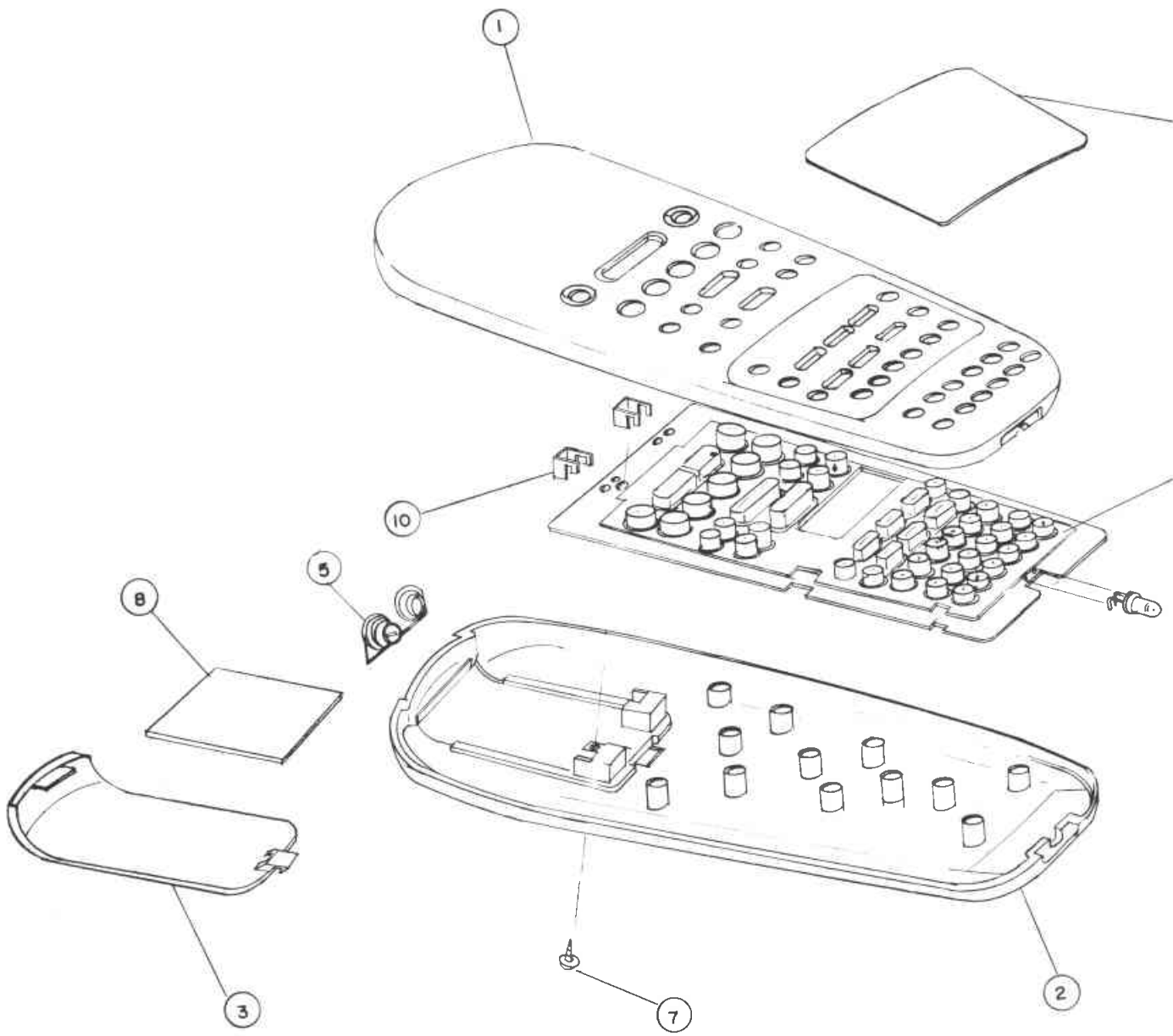

12. REMOTE ASSEMBLY

Ref. No.	Part No.	Description
1	MJAF-01340-ZZ2	COVER-UPPER
2	MJAF-01350-ZZ2	COVER-BOTTOM
3	MJAF-02860-ZZ3	COVER-BATTERY
4	MLAC-09372-ZZ4	PLATE-NAME
5	MPAC-10580-004	BATTERY-SPRING
6	MRAF-01362-ZZ2	PAD-KEY
7	XSTP-25060-ZZ4	SCREW-TAPPING
8	YSAP-09860-004	CUSHION BATTERY
9	YUAP-09640-004	POLY-BAG
10	MMAC-09350-004	TERMINAL-CHARGE

NOTE :

Parts will not be supplied if they are not listed in the parts list even if they appear on the assembling illustrations with reference No.

13. ACCESSARY

Ref. No.	Part No.	Description
1	ANTL-00041-E50	ANT LOOP AAN005
2	ANTT-00090-075	ANT-T AFN009

VII. WIRING DIAGRAM

CN1: LEAD WIRE

NO	LENGTH(m/m)	COLOR
1	300	GR
2	300	YE
3	300	OR
4	300	RE
5	300	BR
6	300	BK

CN2 LEAD WIRE

NO	LENGTH(m/m)	COLOR
1	270	BK
2	270	RE
3	270	BR
4	270	VI
5	270	WH
6	270	GY

CN4: FLAT WIRE

NO	LENGTH(m/m)	COLOR
1	210	WHITE
2	210	YELLOW
3	210	YELLOW
4	210	YELLOW
5	210	YELLOW
6	210	YELLOW
7	210	YELLOW
8	210	YELLOW
9	210	YELLOW

CDP MECHANISM CDKM-87TK3
PICK UP SF-90

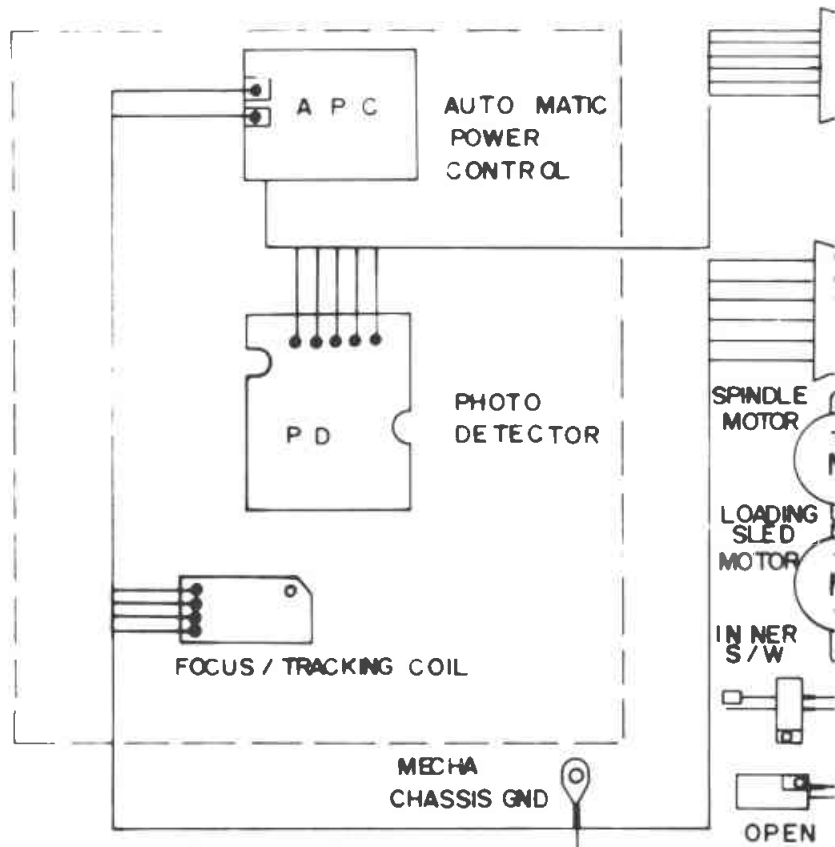

CN3 LEAD WIRE

NO	LENGTH(m/m)	COLOR	REMARK
1	280	YE	
2	280	GY	
3	420	RE	
4	420	WH	
5	260	BL	
6	260	BL	
7	260	OR	
8	260	OR	
9	260	GR	W/LUG

CN5: FLAT WIRE

NO	LENGTH(m/m)	COLOR
1	210	WHIT
2	210	GREI
3	210	GREI
4	210	GRE
5	210	GRE
6	210	GREI
7	210	GREI

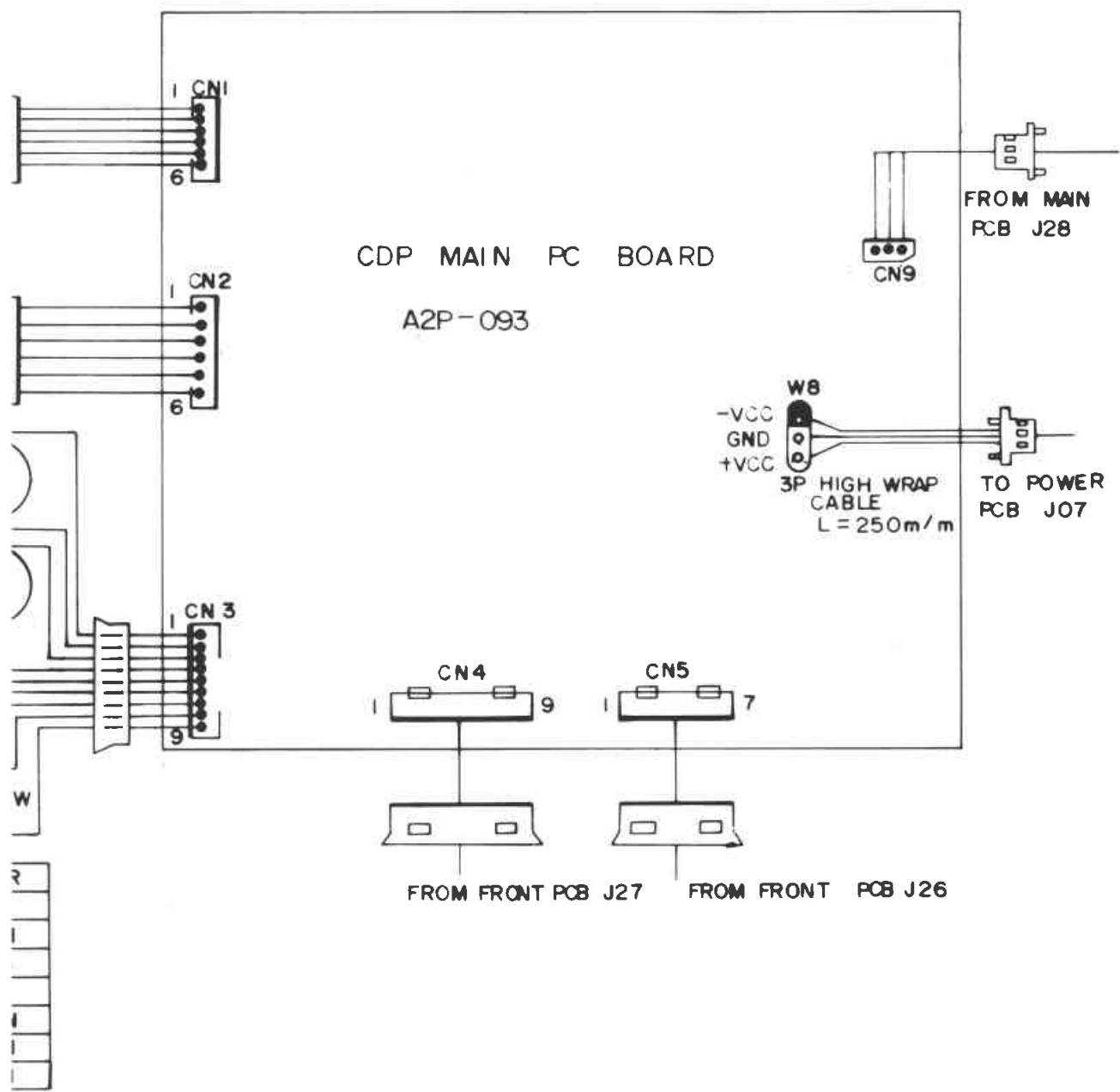

VII. WIRING DIAGRAM

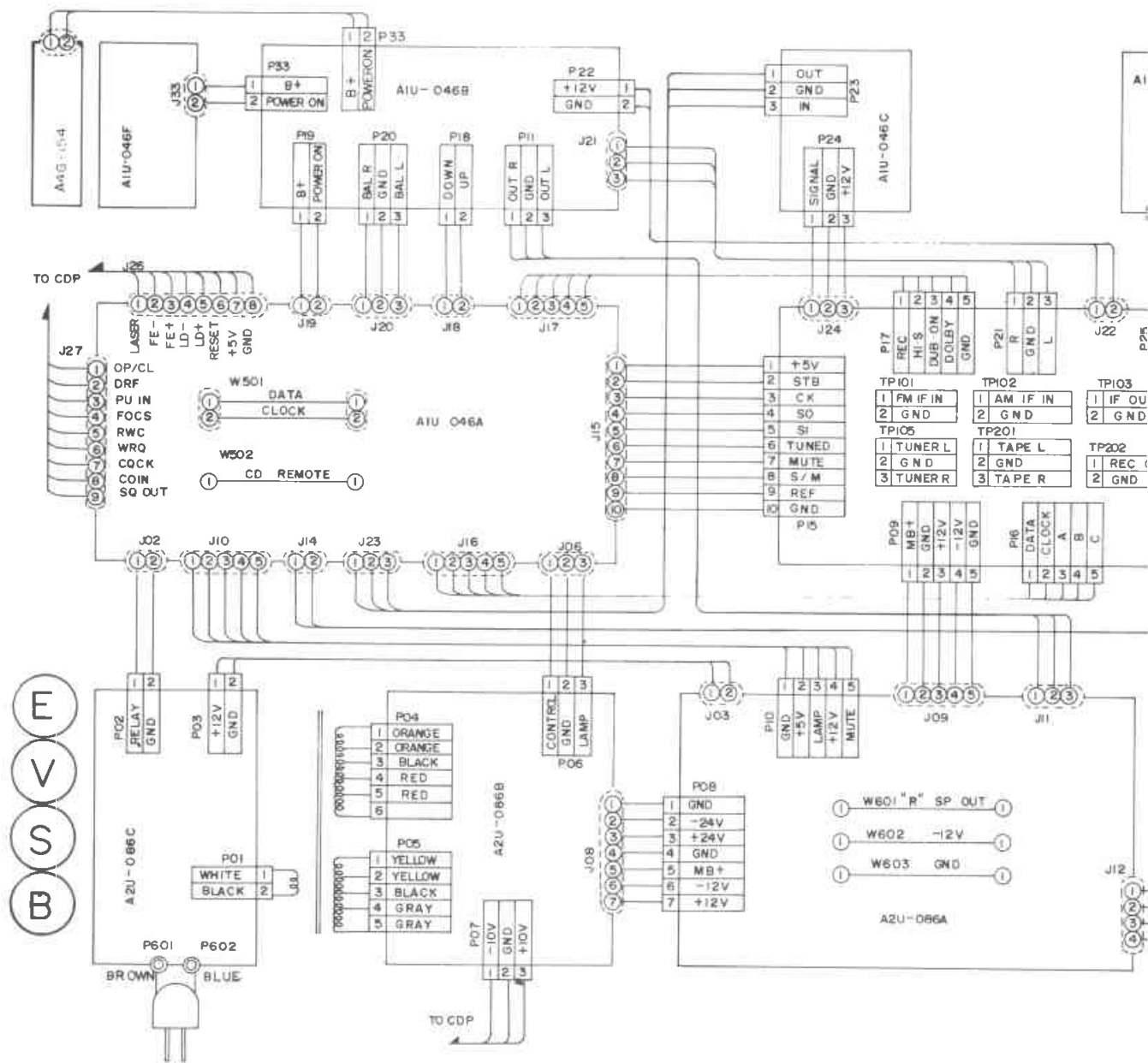

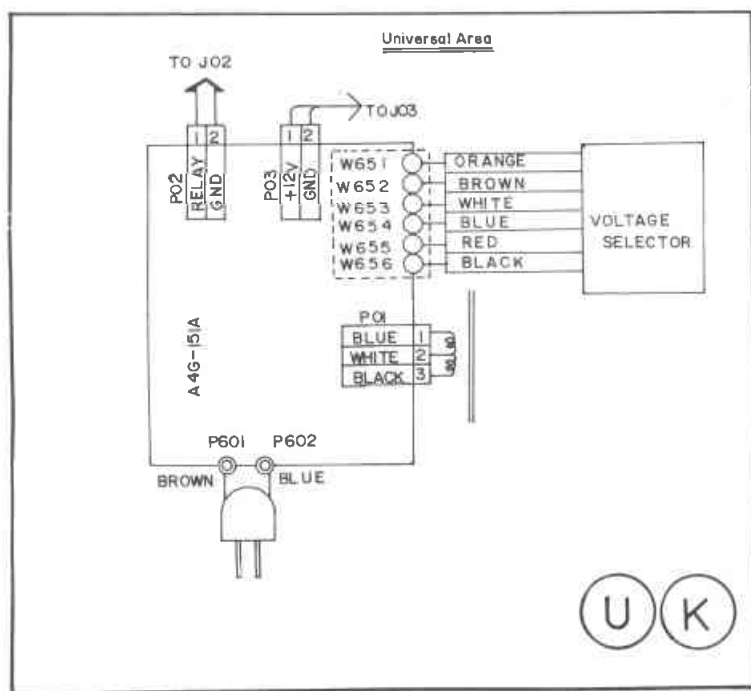
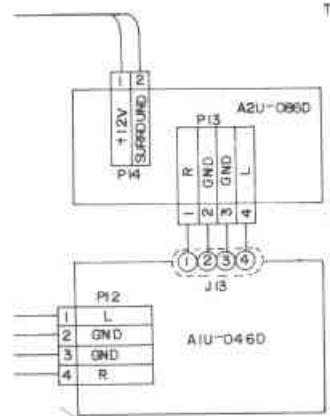
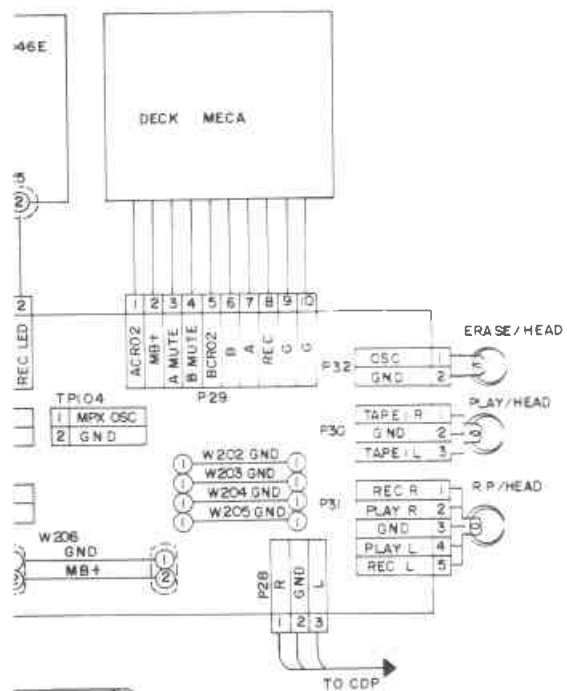

U K

VIII. SCHEMATIC DIAGRAM (CD)

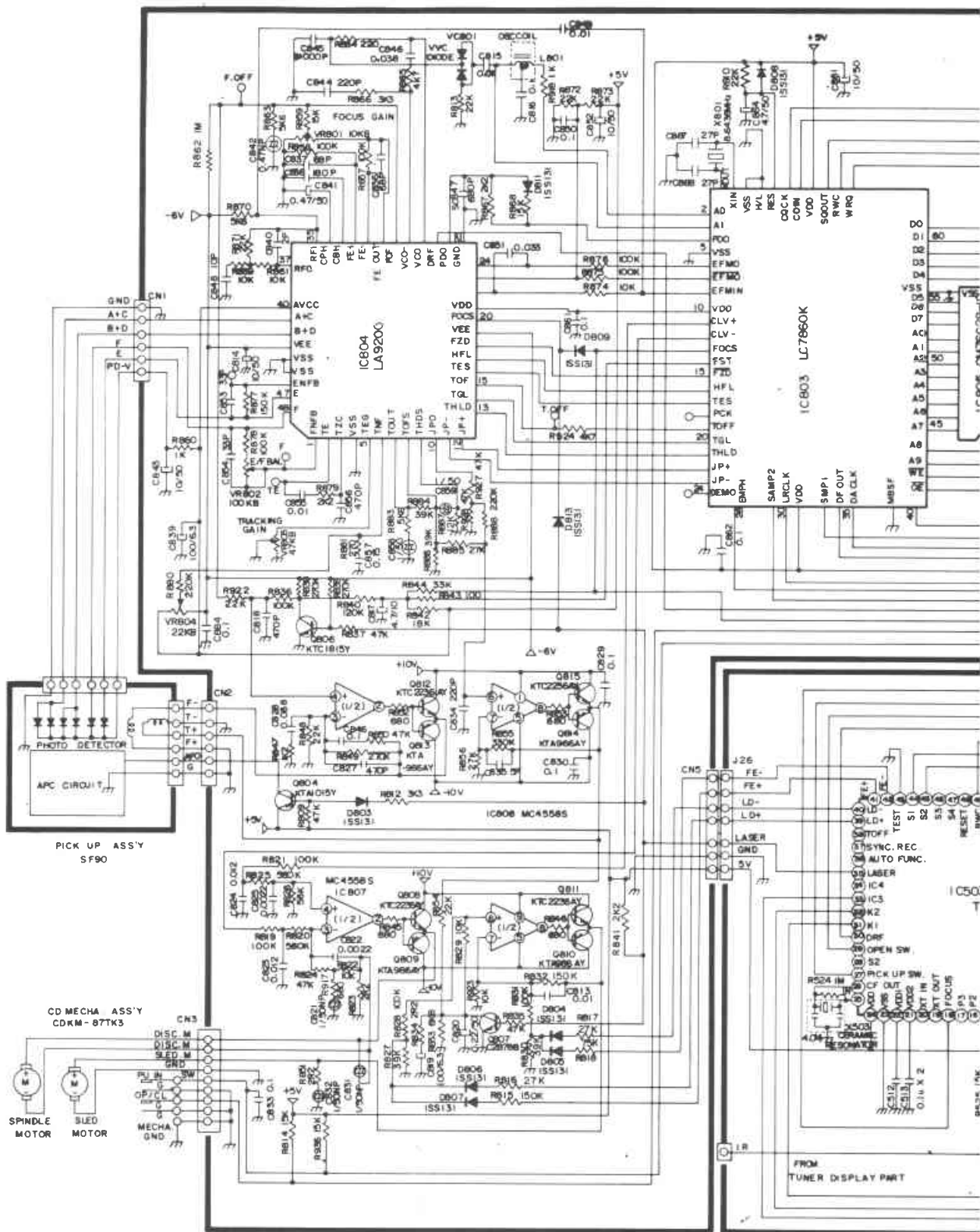

VIII. SCHEMATIC DIAGRAM (EQ. AMP. DECK)

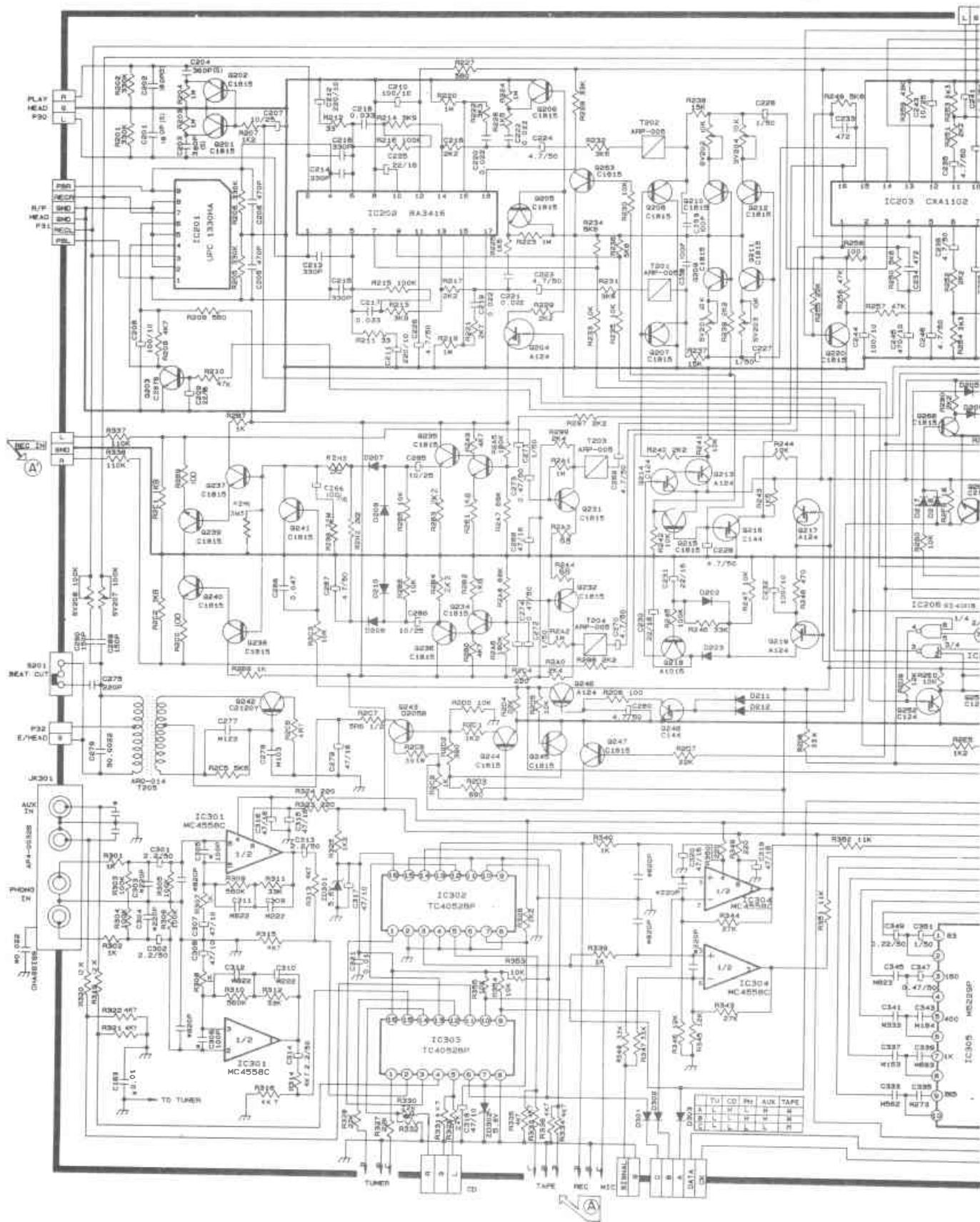

VIII. SCHEMATIC DIAGRAM (FRONT)

THE EXCHANGE FOR BUYER'S OPTION	VERSION	(E) (B), 3BAND, LW	(S), (V), 3
STANDARD; LW	ADDITION	D507, D509, D513	D508, D510
* ALL DIODES ARE IS2472	DELETION	D508	D507, D510
	STEP	AM: 09K, FM: 50K	AM: 09K, FM: 50K

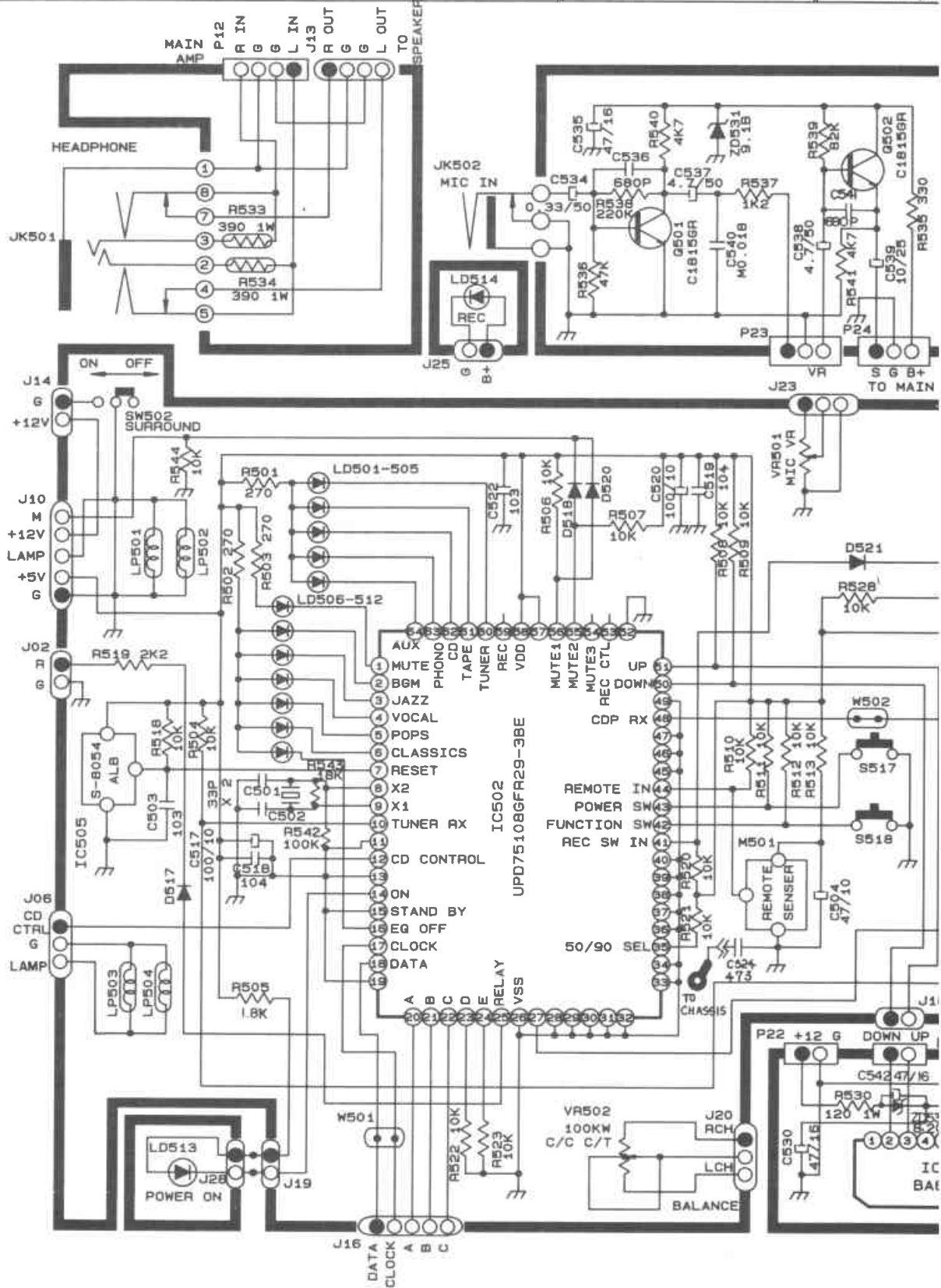

AND	(U), (K) 2BAND	(U), 2BAND	(U), 3BAND, SW
	D508, D513	D507, D508	
	D507, D509	D509, D513	
OOK	AM:109K, FM:100K	AM:10K, FM:100K	

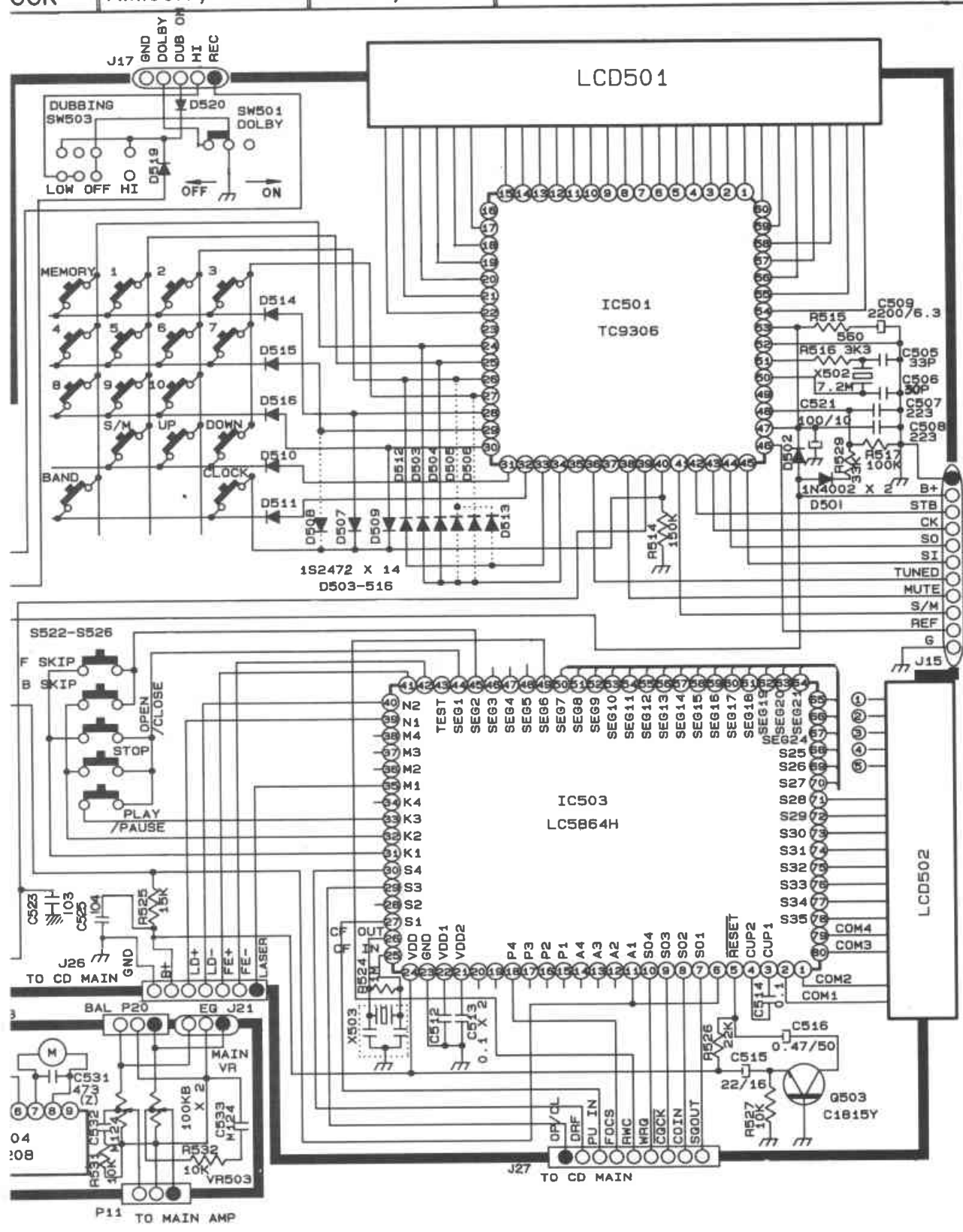

VIII. SCHEMATIC DIAGRAM (TUNER LW, SW 3 BAND)

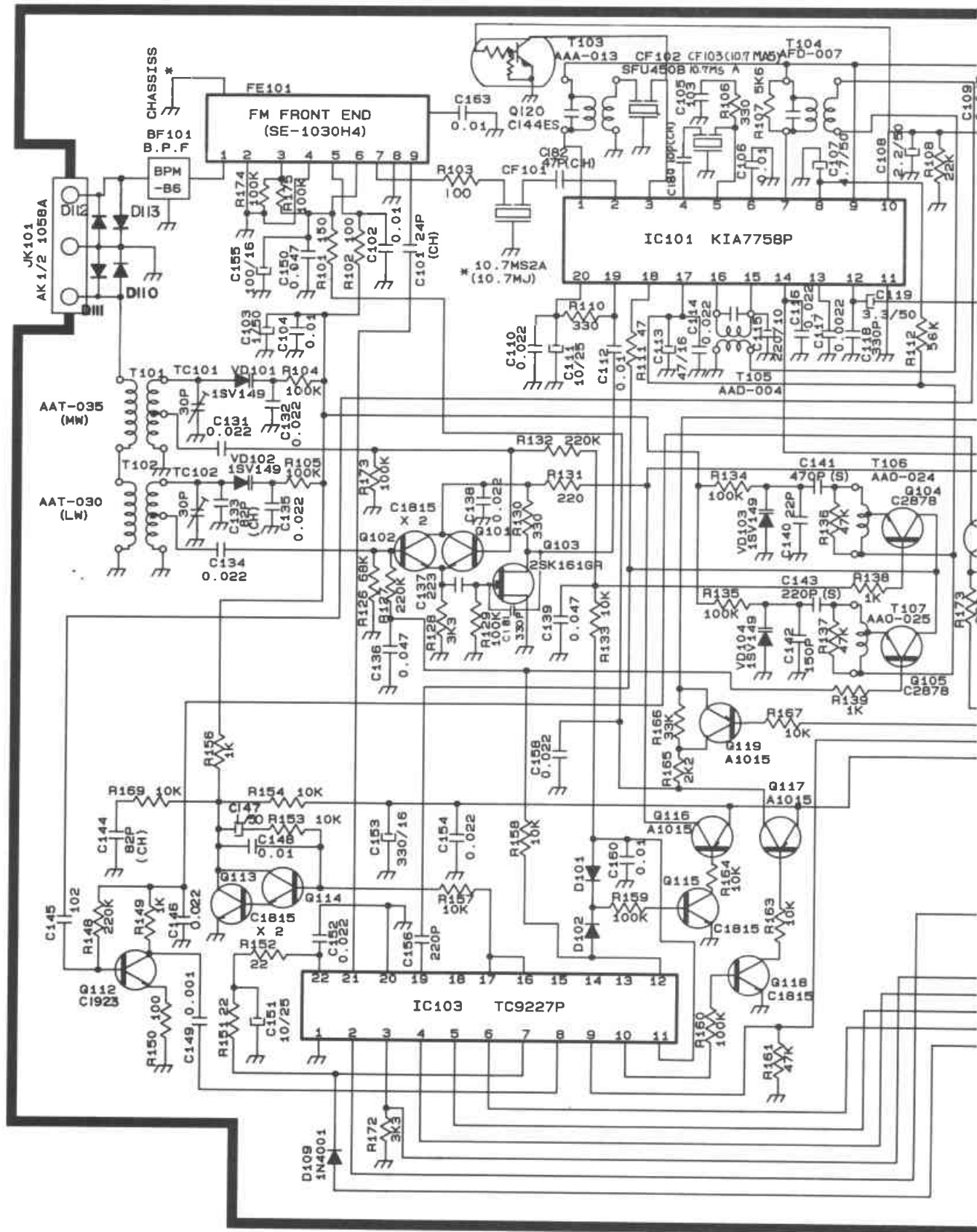

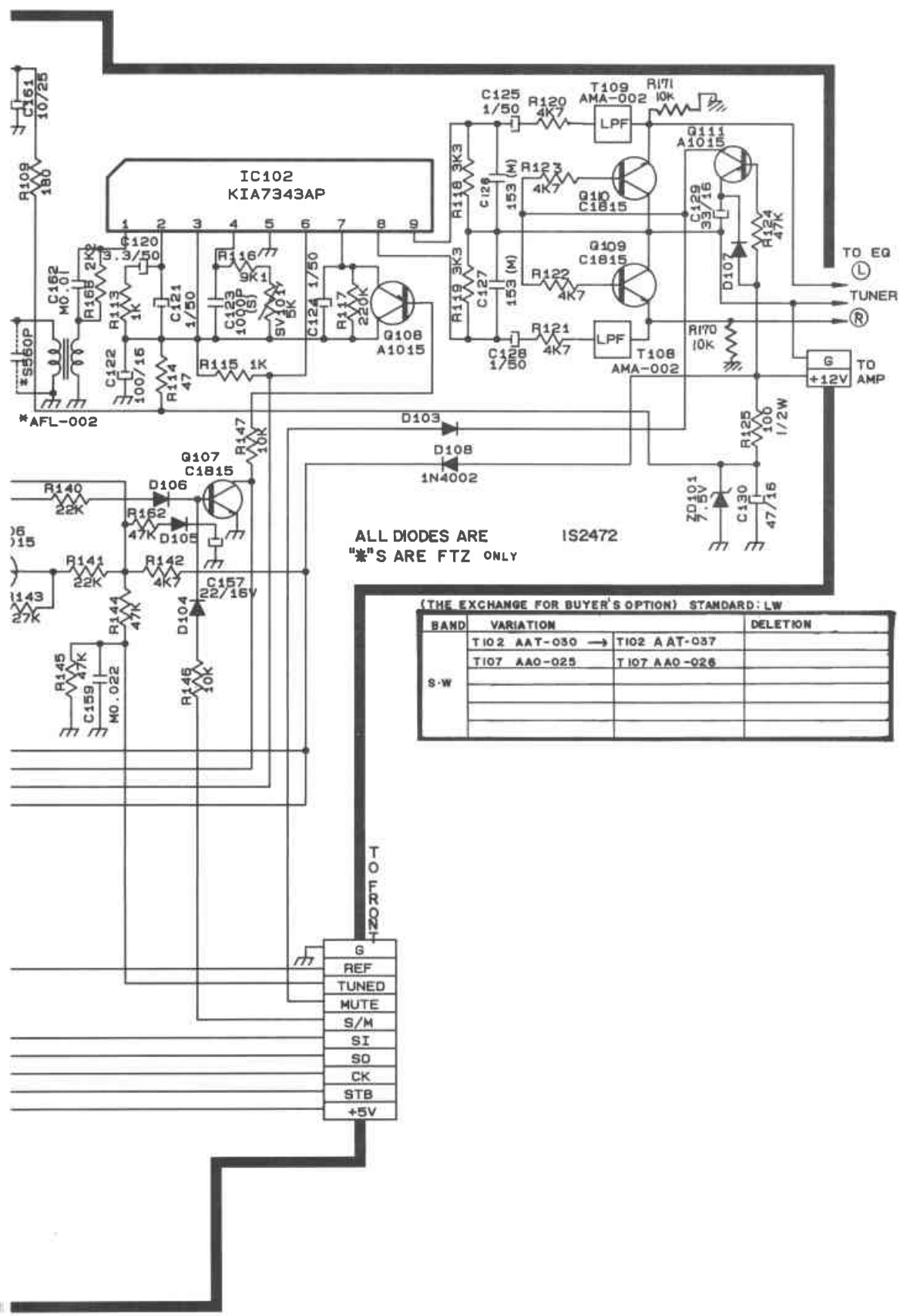

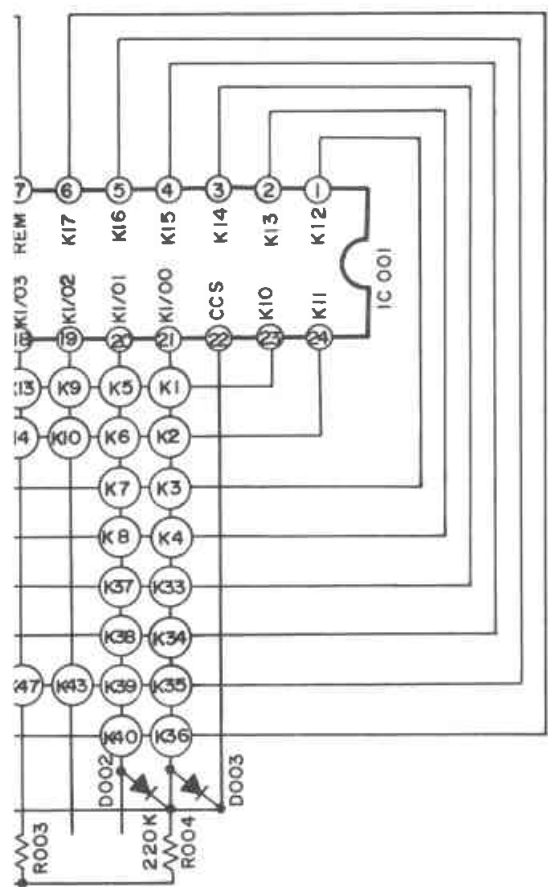

VIII. SCHEMATIC DIAGRAM (AMP)

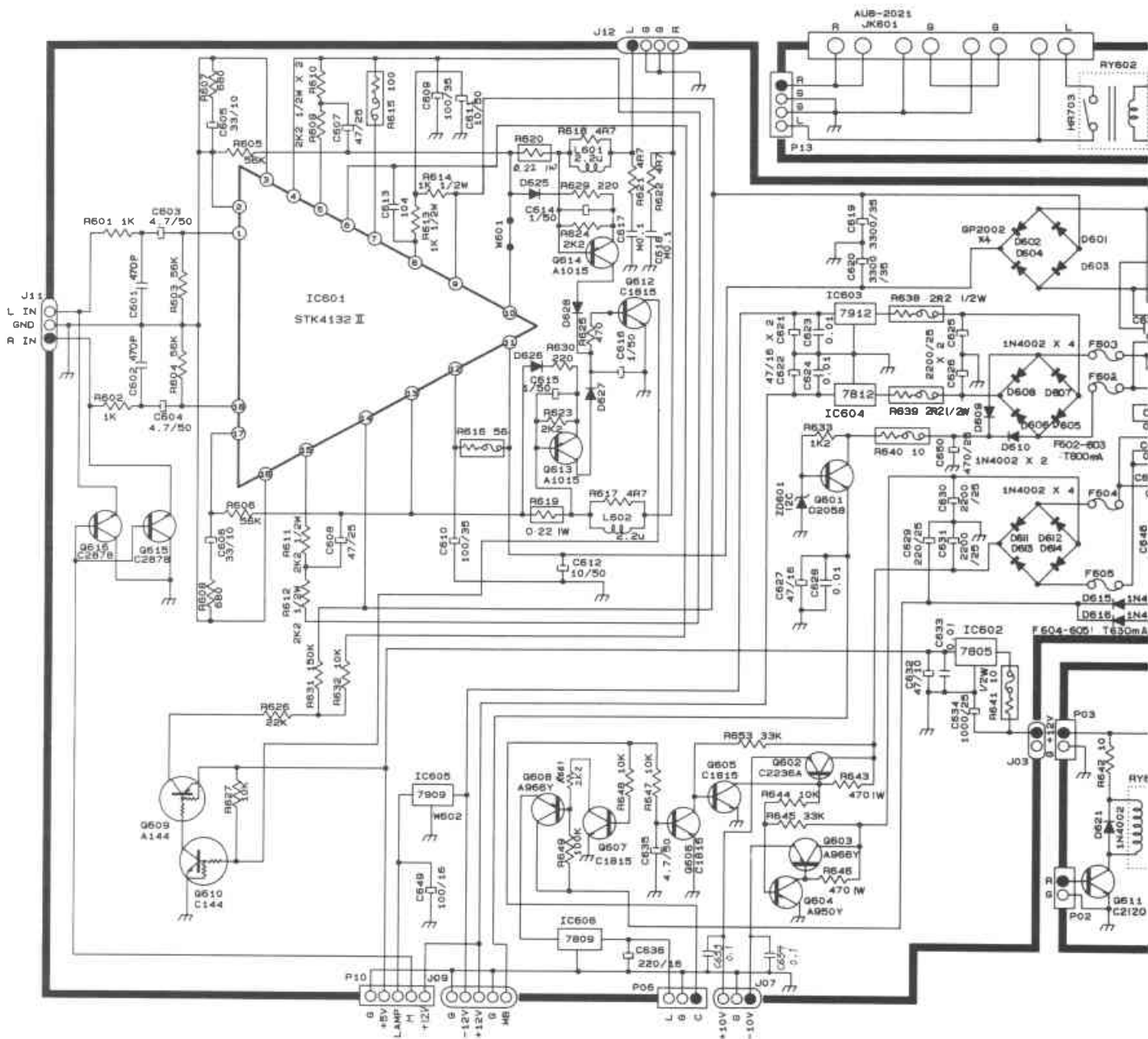

INFORMATION Symbols for primary destination

Alphabet indicates the destination of the units as listed below

SYMBOL	PRINCIPAL DESTINATION	MANE P/T	Location	SUB I
E,V	Europe, Germany	A74-054X-S	PT602	A35-082
S,B	Australia, UK	A74-054Z-B	PT602	A35-082
U,K	Universal Area, KOREA	A74-054BX-K	PT602	A35-082

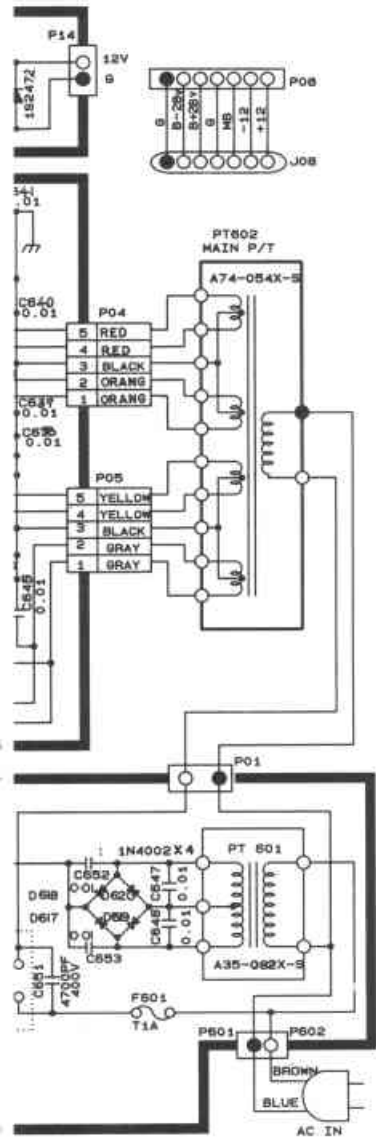

UNIVERSAL-AREA

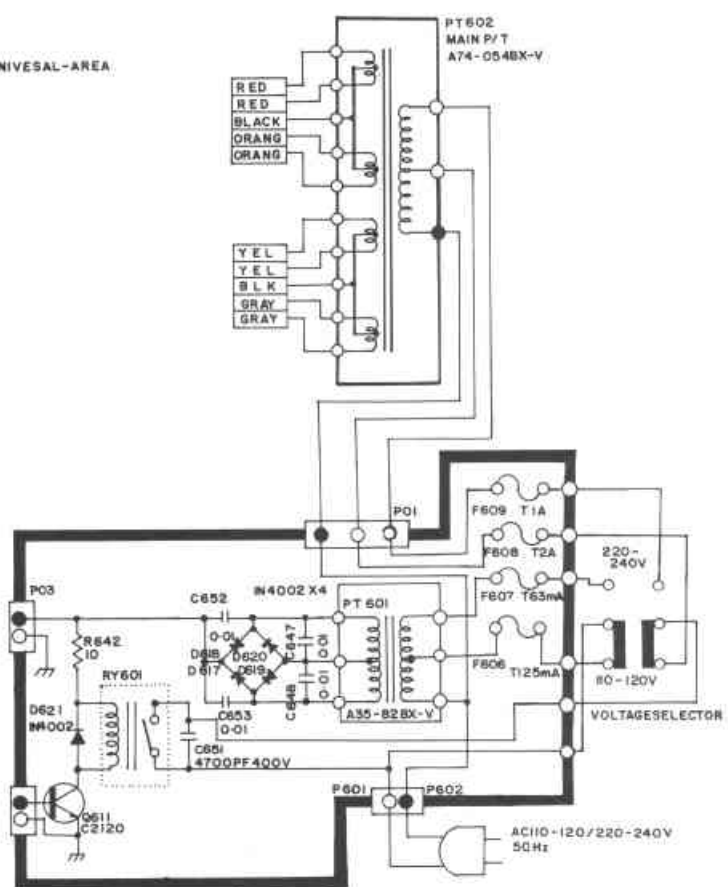

Location	PRIMARY FUSE	Location
S PT601	AC 250V T1A	F 601
B PT601	AC 250V T1A	F 601
HK PT601	AC 250V T1A	F 609
	AC 250V T2A	F 608
	AC 250V T63mA	F 607
	AC 250V T125mA	F 606

IX . PCB LAYOUT

REMOTE PCB

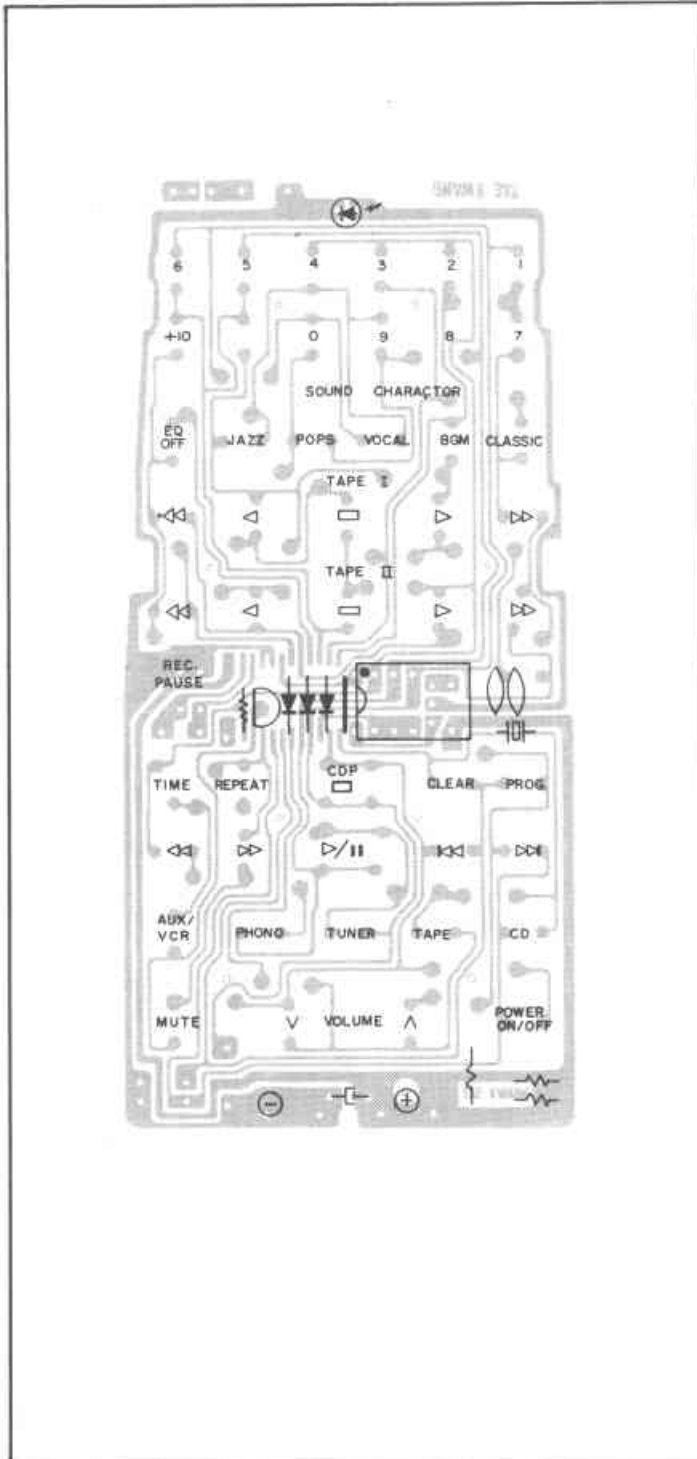

MAIN PCB

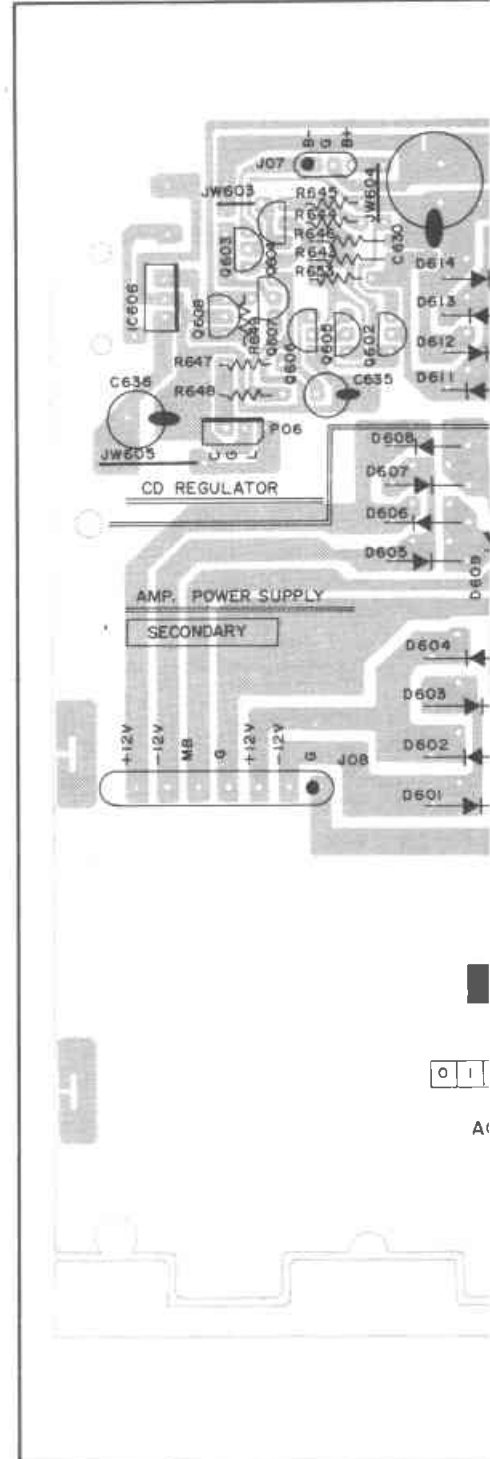

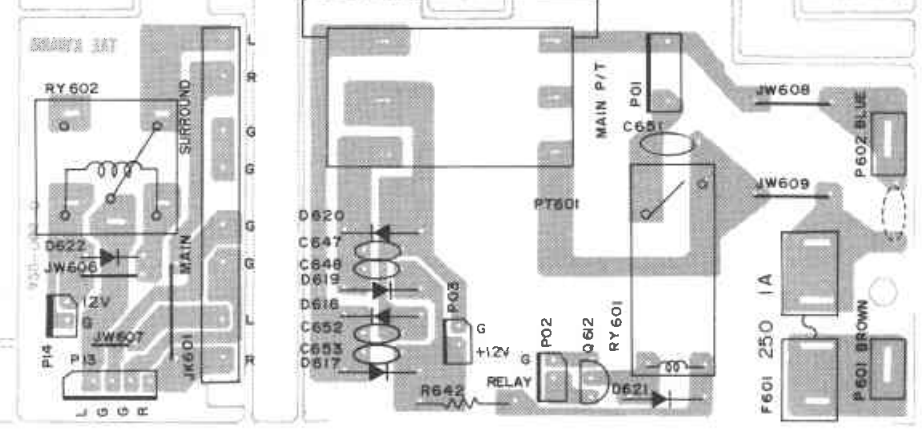
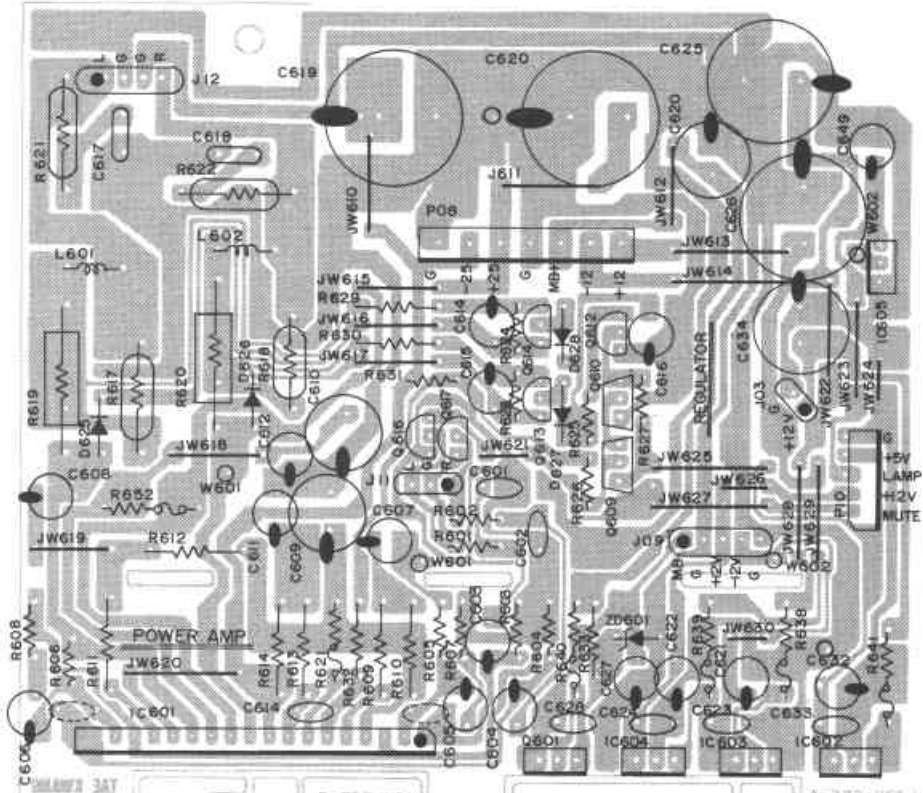
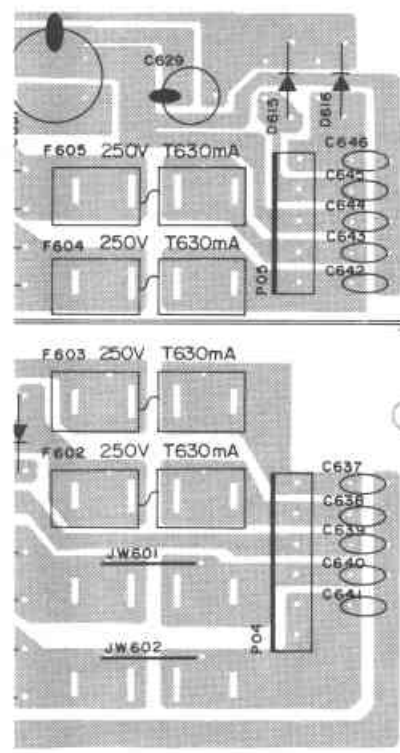

14-000-USA

3AT

3AT

14-000-USA

3-380-USA



3 4 5 6 7 8 9

MX90 AMP PCB

IX.PCB LAYOUT

TUNER/TAPE/EQ

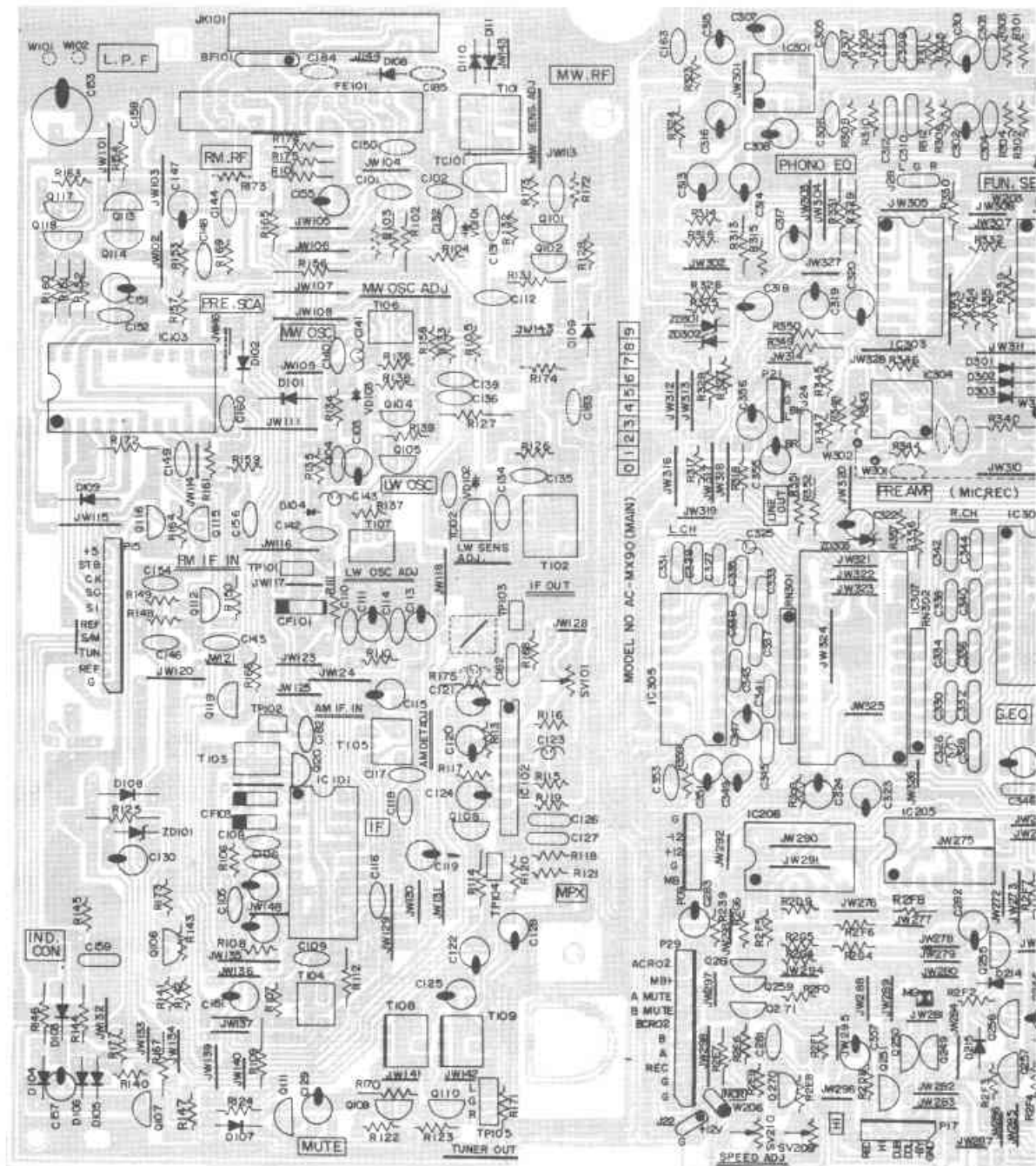

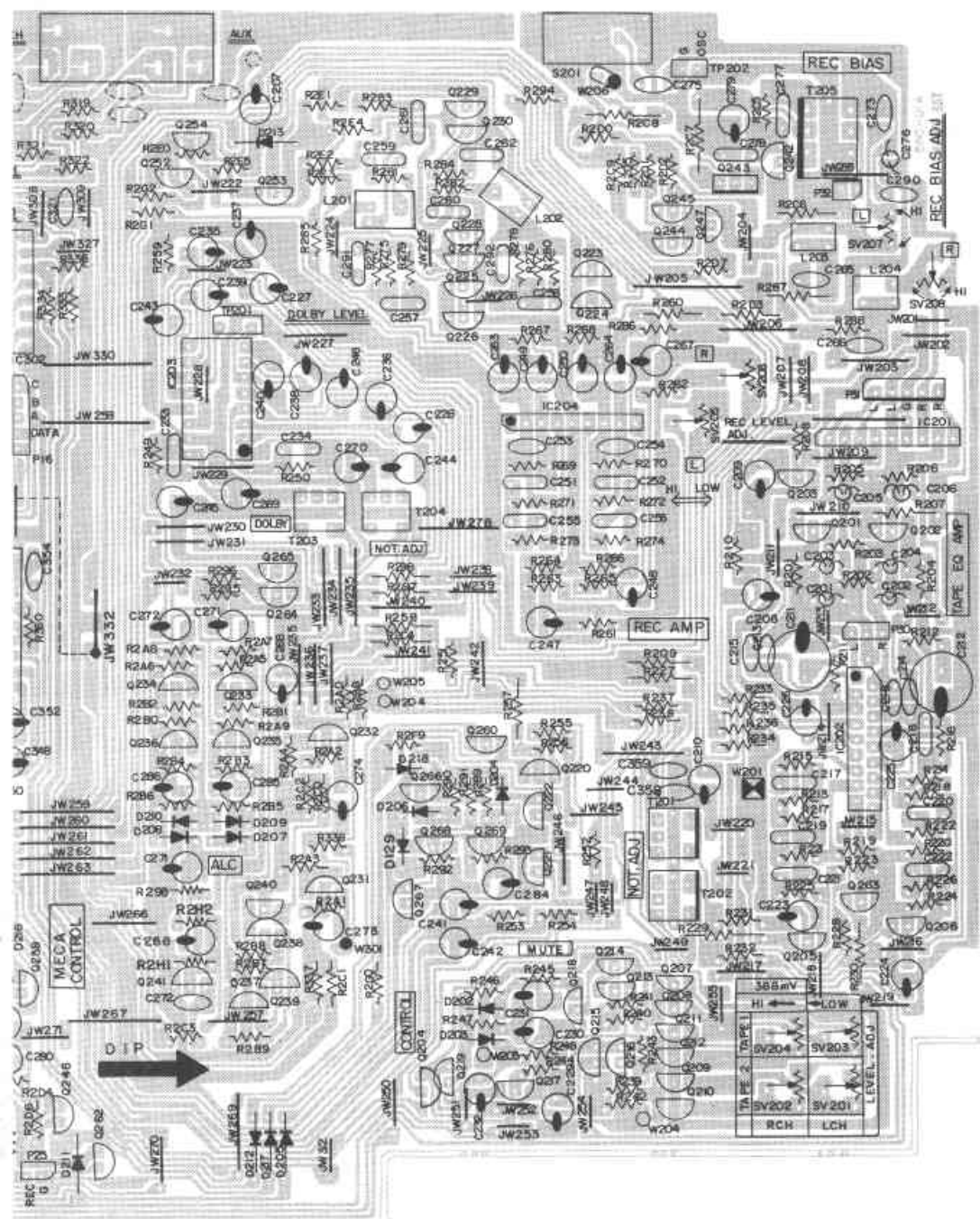

IX. PCB LAYOUT

FRONT PCB

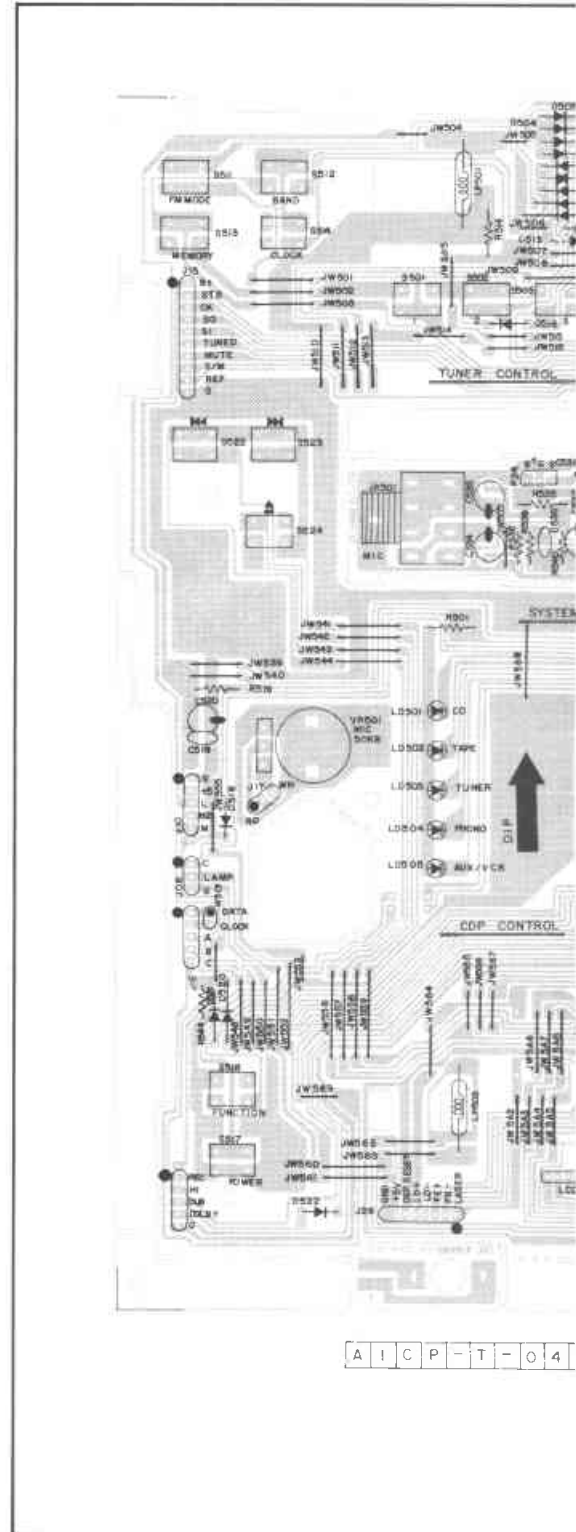

IX. PCB LAYOUT

C.D.P. PCB

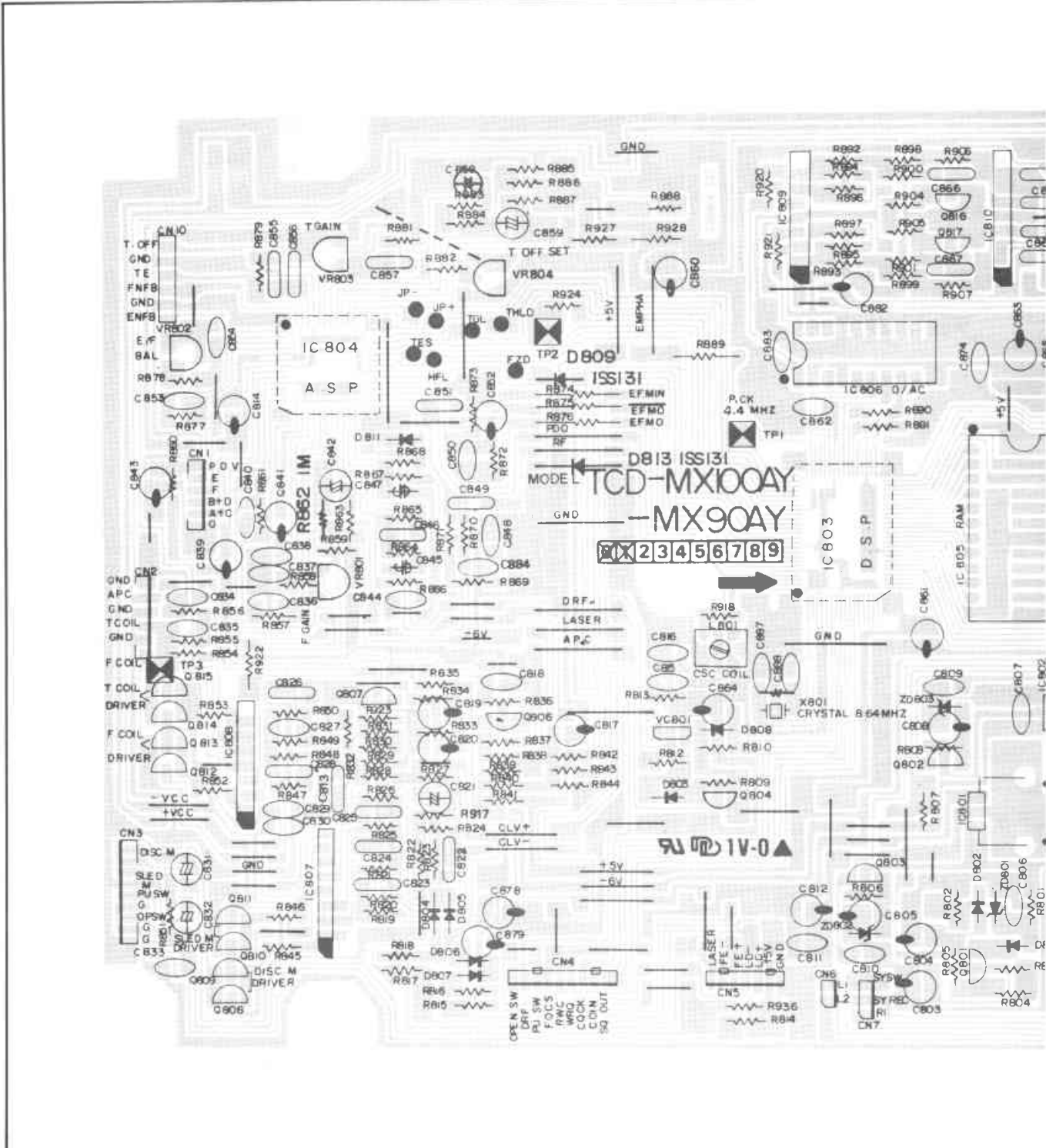

SUB P/T PCB

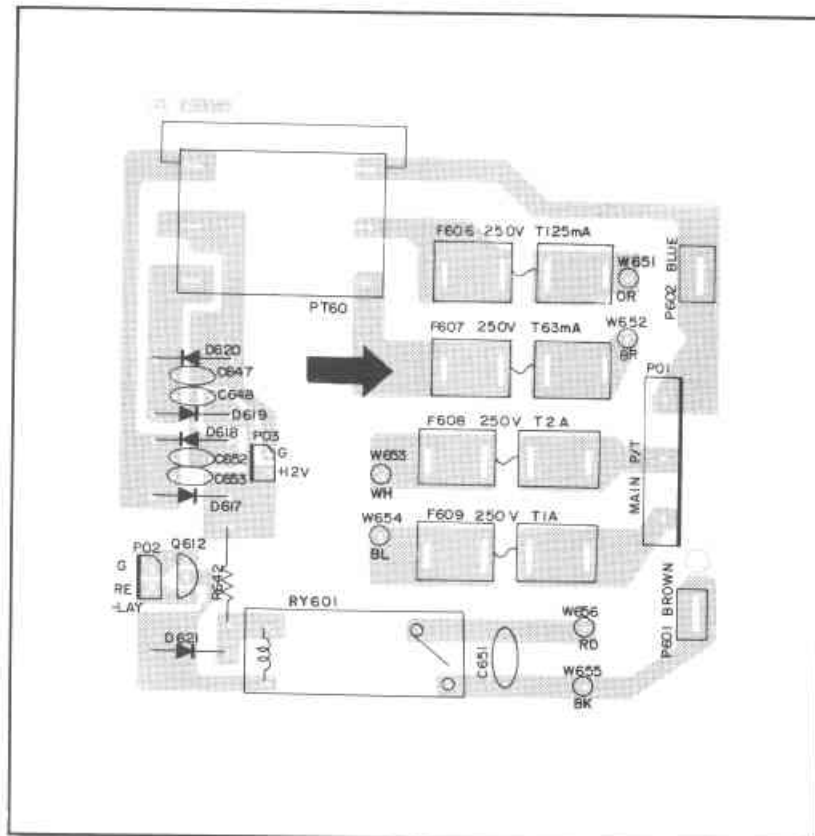
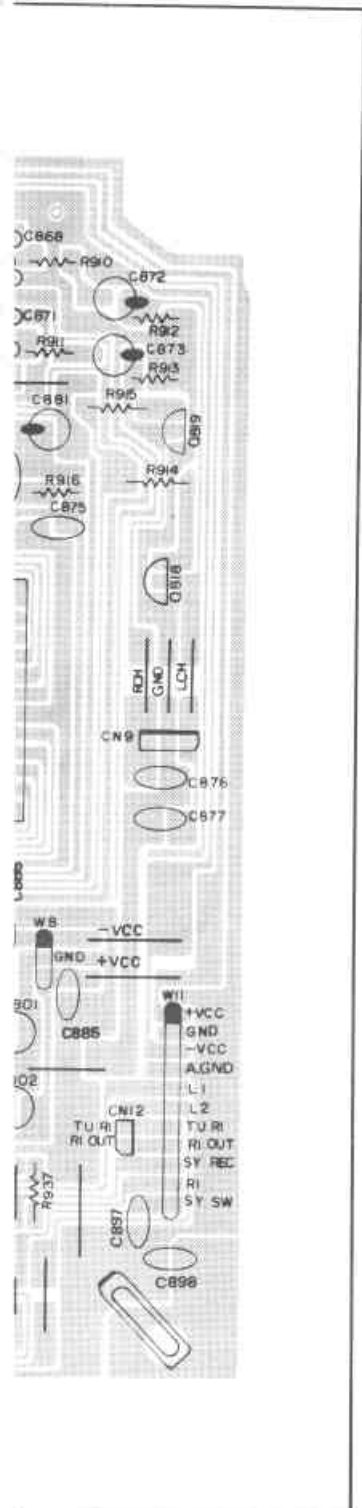

VR LEA PCB



ABBREVIATIONS (CASSETTE)

ABBREVIATION	EXPLANATION	ABBREVIATION	EXPLANATION
AC	Alternating Current	MIN	MINute
A/D	Analog/Digital	MML	Maximum Modulation Level
AF	Auto Fader	MOL	Maximum Output Level
AMP	AMPlifier	MPX	Multi Plex
AR	Anti Recording	NC	Not Connected (No Connection)
AT BIAS	Auto Turning BIAS	NFB	Negative Feed Back
ATT	ATTenuator	NORM	NORMAL
BAL	BALance	NR	Noise Reduction
BEF	Band Elimination Filter	OSC	OSCillator (OSCillation)
BSS	Blank Search System	P	Pulse
CAP M	CAPstan Motor	PB	Play Back
CH	CHannel	OMSS	Quick Memory Search System
COMP	COMParator	OR	Quick Reverse
CONT	CONTinuance	R CH	Right CHannel
CRLP	Computer Recording Level Processing	REC	RECOrd(RECOding)
CS	Chip Select	REV	REVerse
D/A	Digital/Analog	ROT	ROTAtion
DC	Direct Current	REW	REWind
DET	DETEctor	SEC	SECOnd
DISCRI	DISCRIminator	SELE	SELEctor
DUB	DUBbing	SENS	SENSitivity
EQ	EQUALizer	SEPP	Single Ended Push Pull
FF(or F.FWD)	Fast Foward	SIG	SIGNAL
FLD	FLuoresent Display	SPECT	SPECTrum
FREQ	FREQuency	STD	STANdard
FWD	ForWarD	SW	SWitch
GND	GrouND	SYSCON	SYStem CONtroi
H	High	TP	Test Point
HPF	High Pass Filter	TRIG	TRIGa
IND	INDicator	VCA	Voltage Control Attenuator
IPLS	Instant Program Location System	VOL	VOLume
L	Low	VOLT	VOLTage
L CH	Left CHannel	VR	Variable Resistor
LED	Light Emitining Diode	X'TAL	cysTAL
MEMO	MEMOry	X1	Normal speed
MICOM	MICroCOMputer	X2	Dubble speed

ABBREVIATIONS (AMPLIFIER)

ABBREVIATION	EXPLANATION
A	Analog
AC	Alternating Current
AMP	AMPLifier
CD	Compact Disc
COM	COMmon
D	Digital
D/A	Digital to Analog
DAC	Digital to Analog Converter
DAT	Digital Audio Tape recorder
DC	Direct Current
GND	GrouND
L	Left
LED	Light Emitting Diode
MC	Moving Coil
MM	Moving Magnet
PCB	Printed Circuit Board
R	Right
REG	REGulator
REC	RECORD
TR	TRansistor
SW	SWitch
V.AMP	Voltage AMPLifier
V.DISC	Video DISC
VR	Variable Resistance
VTR	Video Tape Recorder

ABBREVIATIONS (TUNER)

ABBREVIATION	EXPLANATION	ABBREVIATION	EXPLANATION
AFC	Auto Frequency Control	MEMO	MEMOry
AGC	Auto Gain Control	MI-COM	Micro-COMputer
ALC	Auto Level Control	MIN	MINimum
AM	Amplitude Modulation	MIX	MIXing
AMP	AMPlifier	MPX	Multi pleX
ANT	ANTenna	MW	Medium Wave(frequency)
BATT	BATTery	NC	No Connection
BLK	BLocK	NFB	Negative Feed Back
BUFF	BUFFer	OSC	OSCillator
COMP	COMPalator	PCB	Printed Circuit Board
DET	DETECT(DETctor)	PLL	Phase Lock.ed Lood
FLD	FLuorescent Display	Q.D	Quadrature Detector
FM	Frequency Modulation	Rch	Right channel
FREQ	FREQuency	REF	REFeRence
GND	GrouND	REG	REGulator
H	High	RF	Radio Frequency
HPF	High Pass Filter	SEG	SEGment
IF	Intermediate Frequency	SELE	SELEctor
IHF	Institut of High Fidelity	SENS	SENSitivity
IND	INDicator	SIG	SIGnal
I/O	In/Out	S/N	Signal to Noise Ratio
JW	Jumper Wire	SSG	Standard Signal Generator
L	Low	STD	STanDard
LCD	Liquid Crystal Display	SW	SWitch : Short Wave(frequency)
Lch	Left channel	THD	Total Harmonic Distortion
LED	Light Emiting Diode	TP	Test Point
LPF	Low Pass Filter	VCO	Voltage Controlled Oscillator
LW	Long Wave(Frequency)	VR	Variable Resistor
		X'TAL	Crystal

AKAI ELECTRIC CO., LTD.

12-14, 2-Chome, Higashi-Kojiya, Ohta-ku, Tokyo, Japan
SERVICE DEPARTMENT TEL : TOKYO(745)9884 TELEX : J26261

Printed Date : OCT. 30, 1991

Printed in Korea